

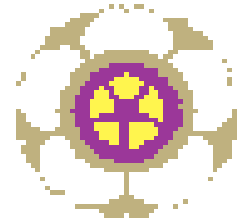

Charmonium(-like)  
(and charm)  
spectroscopy at Belle



2007 July 8th

Kenkichi Miyabayashi(Nara WU)

Seminar at RCNP

# KEKB accelerator

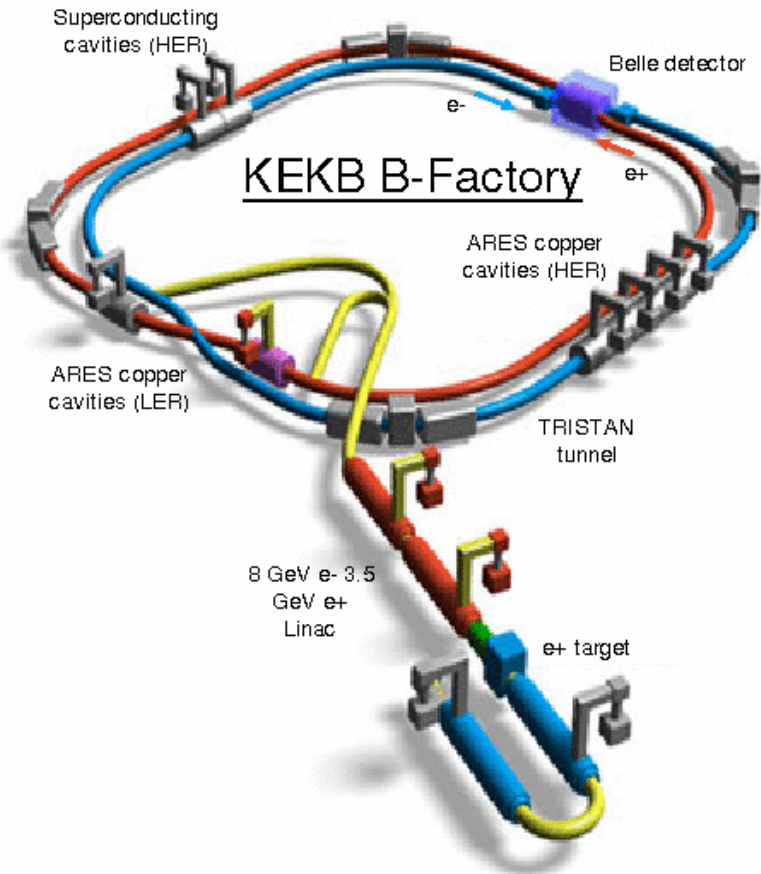

8GeV(e<sup>-</sup>)X3.5GeV(e<sup>+</sup>)  
 3km double ring  
 Peak lum.>1.7X10<sup>34</sup>cm<sup>-2</sup>s<sup>-1</sup>

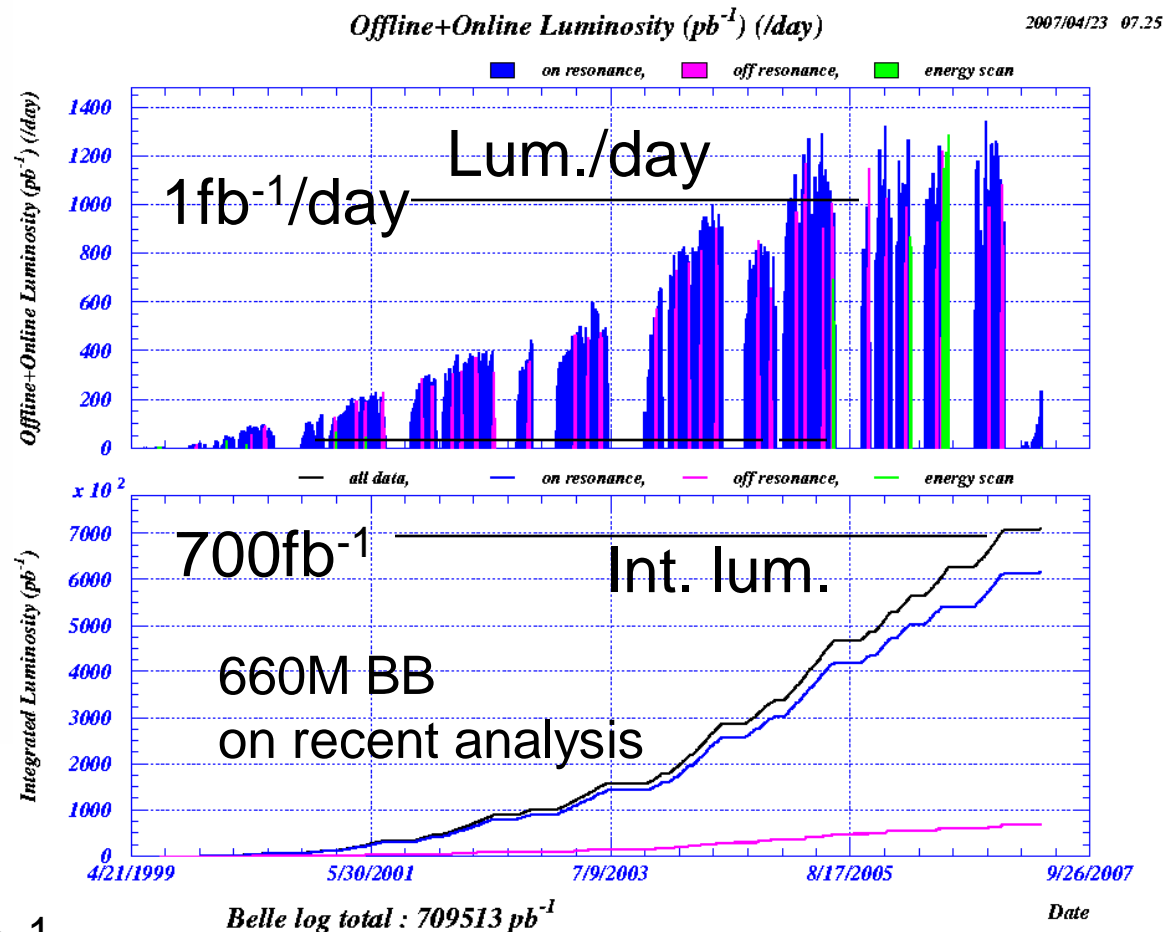

# Why so high luminosity energy-asymmetric $e^+e^-$ collider?

PDG2006

## Charmonium modes

$\Gamma_{134}$	$\eta_c K^0$	$(9.9 \pm 1.9) \times 10^{-4}$
$\Gamma_{135}$	$\eta_c K^*(892)^0$	$(1.6 \pm 0.7) \times 10^{-3}$
$\Gamma_{136}$	$J/\psi(1S)K^0$	$(8.72 \pm 0.33) \times 10^{-4}$
$\Gamma_{137}$	$J/\psi(1S)K^+\pi^-$	$(1.2 \pm 0.6) \times 10^{-3}$
$\Gamma_{138}$	$J/\psi(1S)K^*(892)^0$	$(1.33 \pm 0.06) \times 10^{-3}$
$\Gamma_{139}$	$J/\psi(1S)\eta K_S^0$	$(8 \pm 4) \times 10^{-5}$

B is so heavy that there are so many decay modes.

→ Need quite a lot of B for exclusive studies.

→ Need to measure time evolution of B

# Belle detector

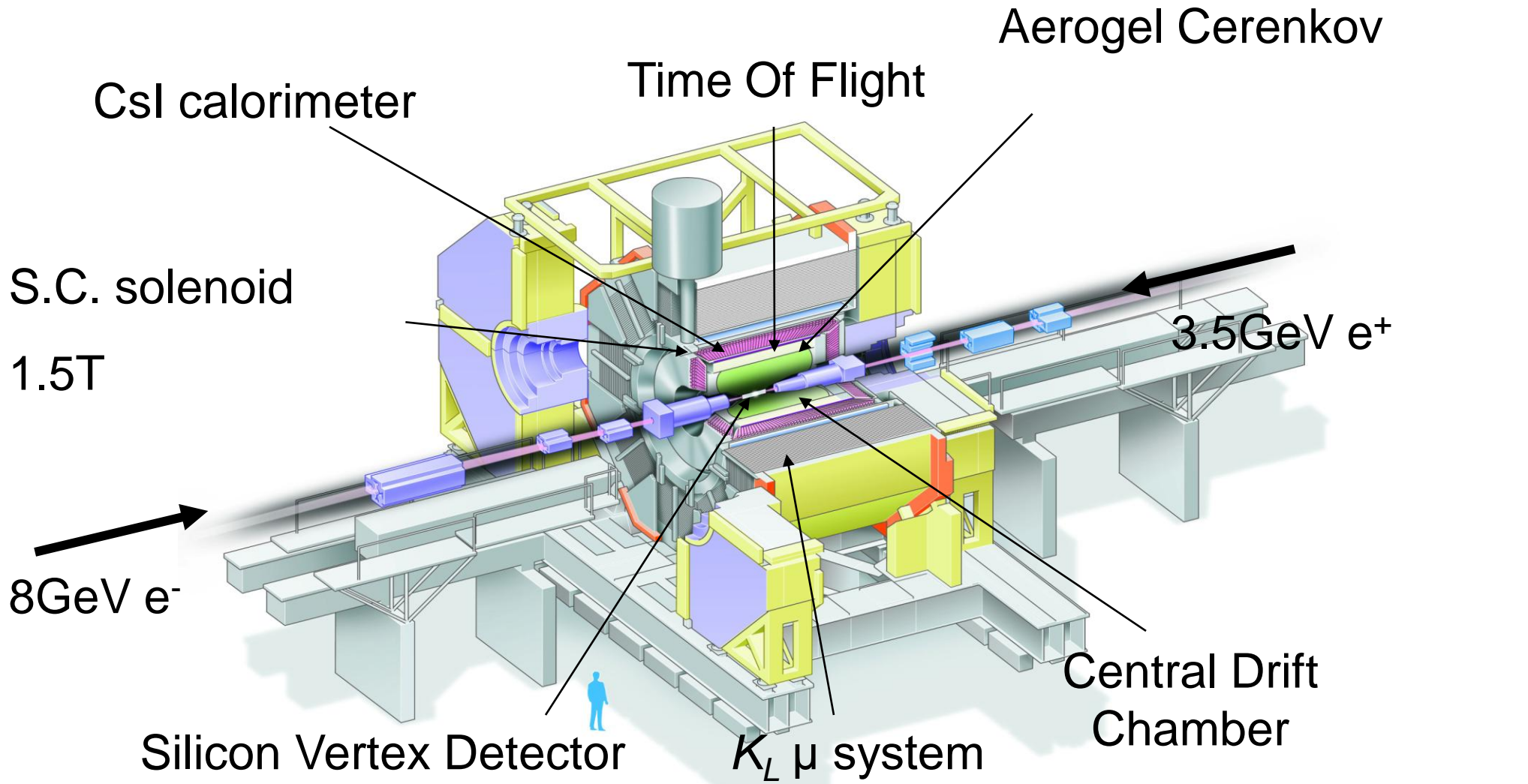

General purpose high-resolution spectrometer with particle-ID capabilities

# As of 2007/July/7th,...



**Belle Journal Publications**  
*The Belle Collaboration*

---

*- Physics Publications*

225. **Search for  $B \rightarrow h^{(*)} \nu \bar{\nu}$  Decays at Belle**  
K.-F. Chen et al. (The Belle collaboration), submitted to PRL  
([Belle preprint 2007-30](#), KEK Preprint 2007-22, [arXiv:0707.0138v1\[hep-ex\]](#))  
[Fig. [1a](#) | [1b](#)] [Fig. [2a](#) | [2b](#) | [2c](#) | [2d](#) | [2e](#) | [2f](#) | [2g](#) | [2h](#) | [2i](#)]
224. **Observation of  $B^0 \rightarrow D^{*+} \tau \nu$  decay at Belle**  
A. Matyja, M. Rozanska et al. (The Belle collaboration), submitted to PRL  
([Belle preprint 2007-32](#), KEK Preprint 2007-24, [arXiv:0706.4429\[hep-ex\]](#))  
[Fig. [1a](#) | [1b](#)] [Fig. [2a](#) | [2b](#)] [Fig. [3](#)]
223. **Study of  $B$  to  $p\bar{p}$   $K$  and  $p\bar{p}$   $\pi$**   
J.-T. Wei, M.-Z. Wang et al. (The Belle collaboration), submitted to PLB  
([Belle preprint 2007-26](#), KEK Preprint 2007-15, [arXiv:0706.4167\[hep-ex\]](#))  
[Fig. [1a](#) | [1b](#)] [Fig. [2a](#) | [2b](#)] [Fig. [3a](#) | [3b](#)] [Fig. [4a](#) | [4b](#)] [Fig. [5a](#) | [5b](#) | [5c](#) | [5d](#) | [5e](#) | [5f](#)] [Fig. [6a](#) | [6b](#)]

During 2007, more than 30 papers have been published or submitted (more than 200 from the beginning). Significant portion is related to spectroscopy.



Apparently it is impossible to mention all of them, so ...

# Outline

- $B \rightarrow$  charmonium(-like) decay
  - $X(3872)$  and its quantum number
  - $Y(3940)=X(3495)$
- $X(3490)$  in double charmonium production
- $Z(3930)=\chi_{c2}(2P)$  in two photon process
- $D_{Sj}(2700)$  in  $B^+ \rightarrow D^0\bar{D}^0K^+$
- $\Lambda(2880)^+ J^P$
- Future prospect
- Summary

# Charmonium(-like) states in B decay

B decays as a source of  
“hidden charm”(charm anti-charm )

Cabbibo-favored diagram ( $V_{cb}$  and  $V_{cs}$ ) → commonly produced!

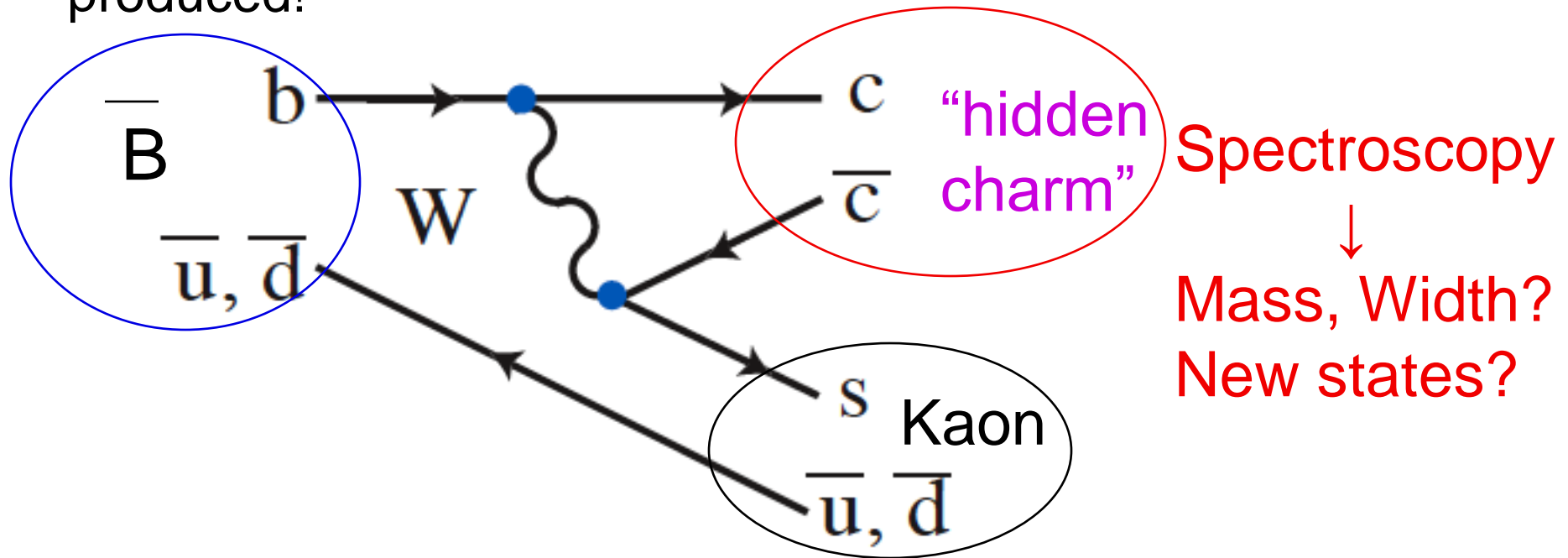

# Reconstruction of charmonium

$J/\psi \rightarrow$  di-lepton decays are reconstructed as a prominent peak.

In di-electron channel, include photons detected near electron/positron tracks to recover Brems. as much as possible in order to reduce radiative tail.

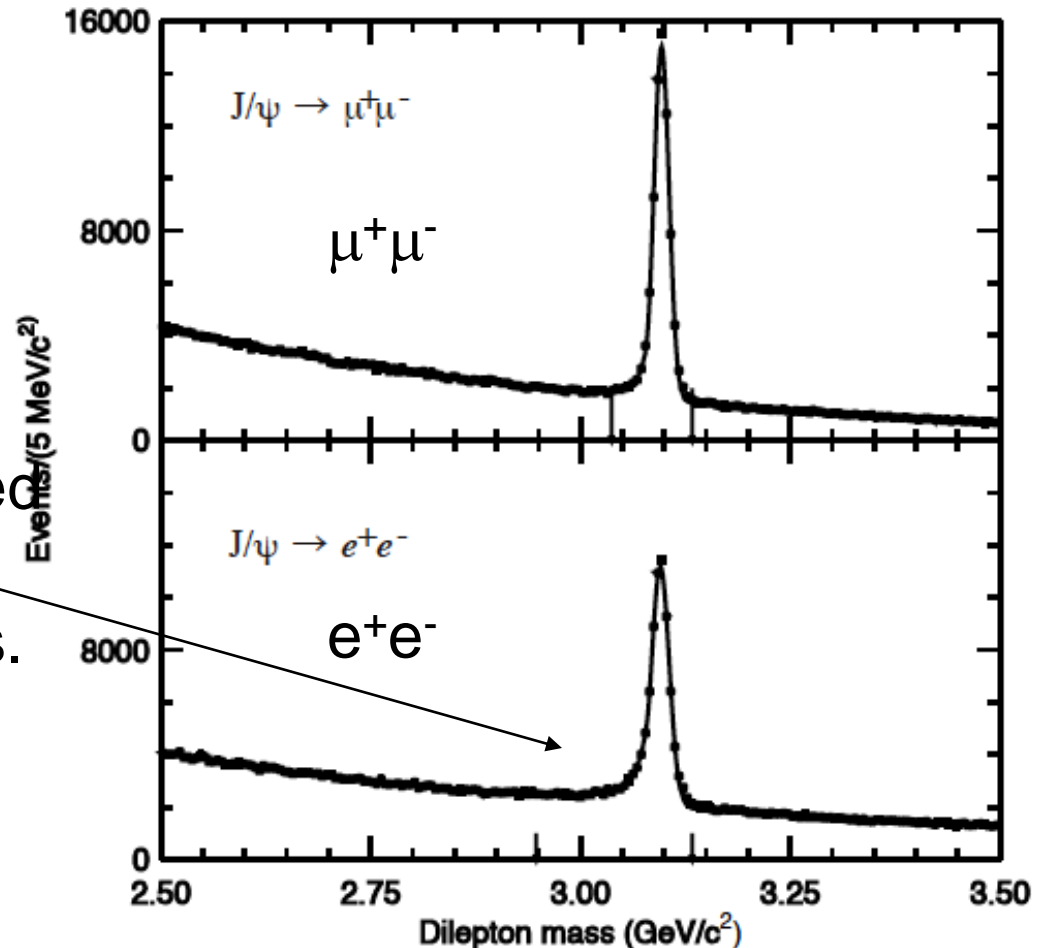

# Reconstruction of charmonium(cont.)

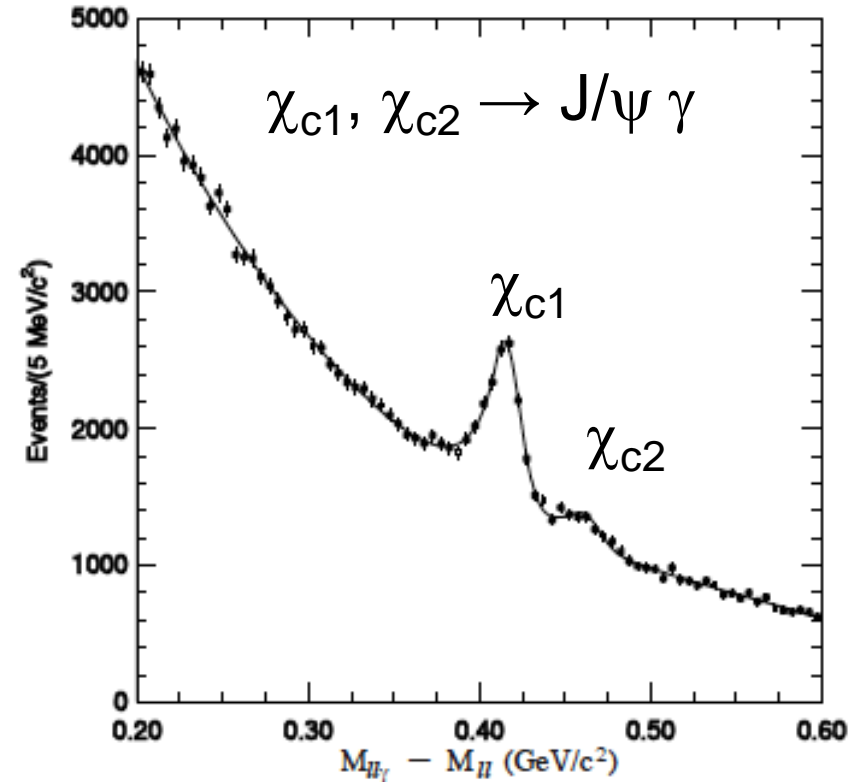
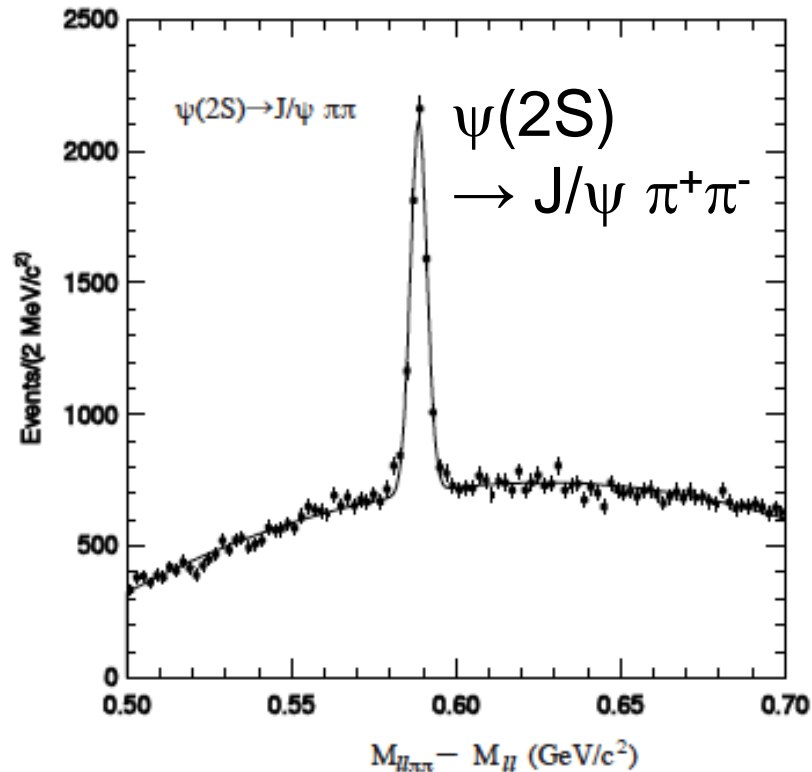

Higher charmonium states ( $\psi(2S)$ ,  $\chi_c$ ) are reconstructed using mass difference.

# Reconstruction of B decays

Example;  $B^0 \rightarrow J/\psi K_S$

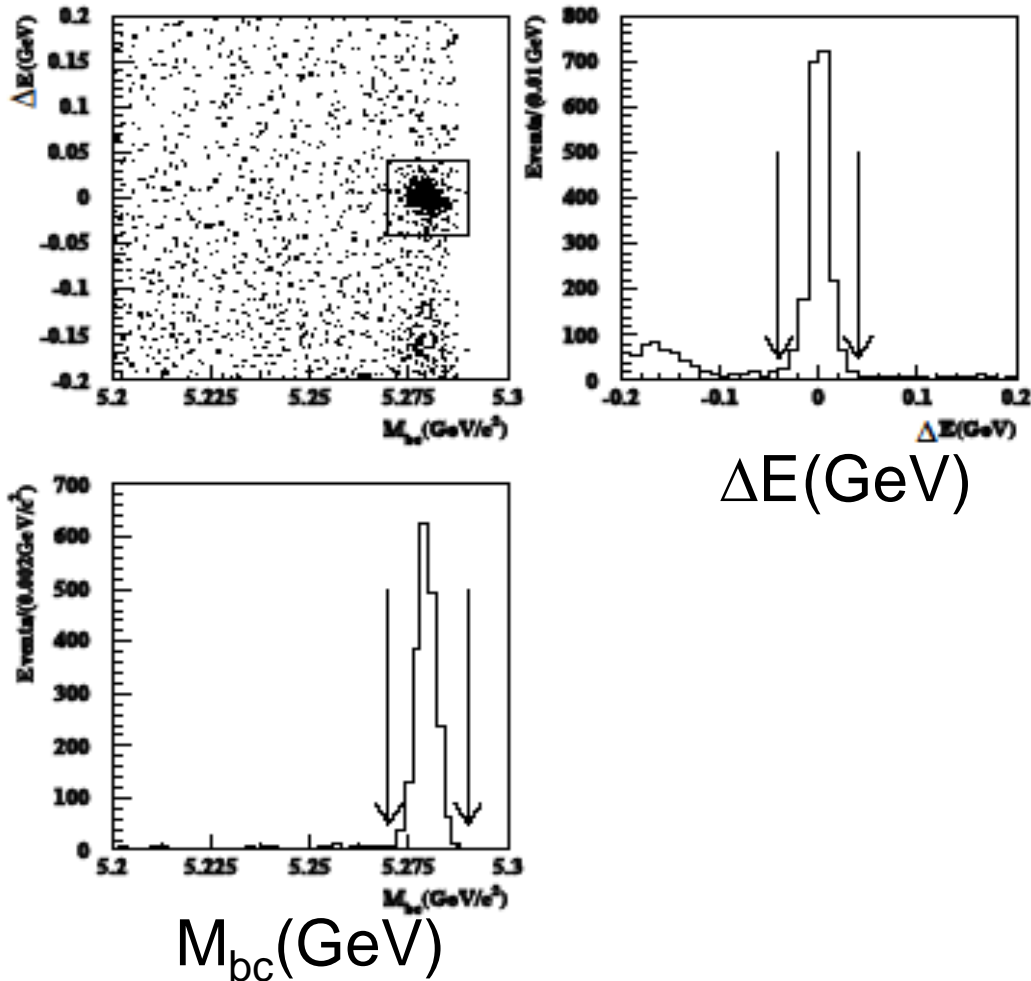

Using  $Y(4S) \rightarrow B\bar{B}$  kinematics

$$M_{bc} = \{ (E_{CM}/2)^2 - (\sum P_i)^2 \}^{1/2}$$

Signal peaks at B mass  
(5.28 GeV)

$$\Delta E = \sum E_i - E_{CM}/2$$

Signal peaks at 0.

# First sensation, peak at 3872 MeV in “look-back” distribution

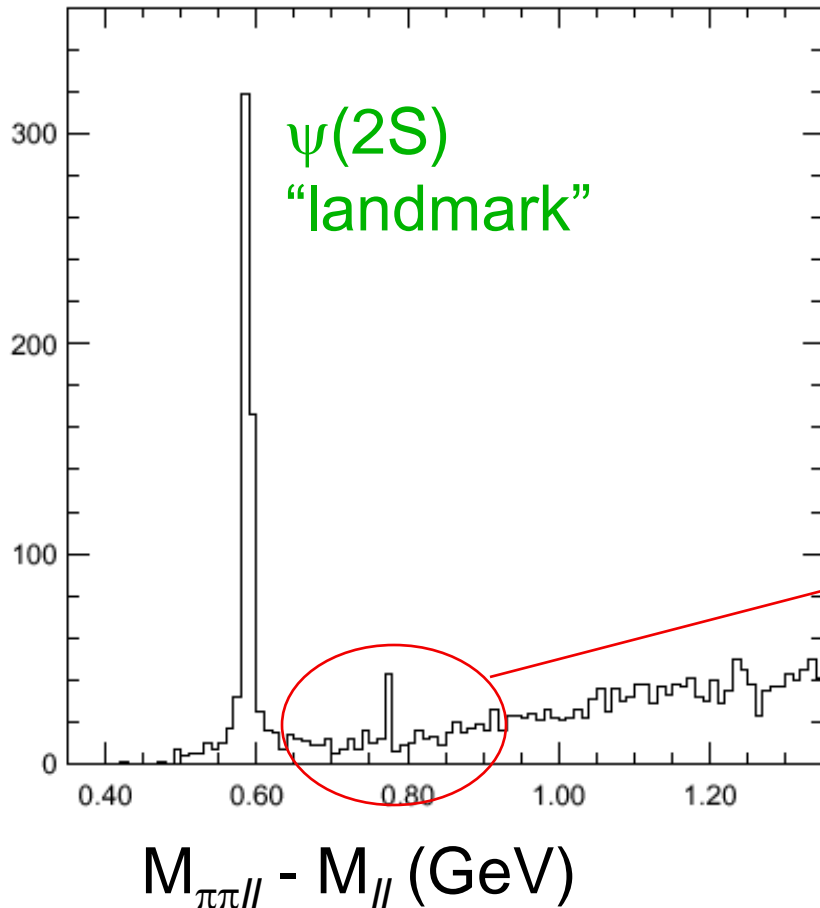

- $K \pi^+ \pi^- J/\psi$  is combined to form a B candidate.

- Using the B candidate’s daughter particles, the mass difference distribution is checked.

Narrow  $\bar{c}$  unknown peak is there, above DD threshold(3.73GeV)!

Belle, 152M BB,  
PRL91,261801(2003)

# Second scoop, $B \rightarrow K\omega J/\psi$ enhancement; $Y(3940)=X(3945)$

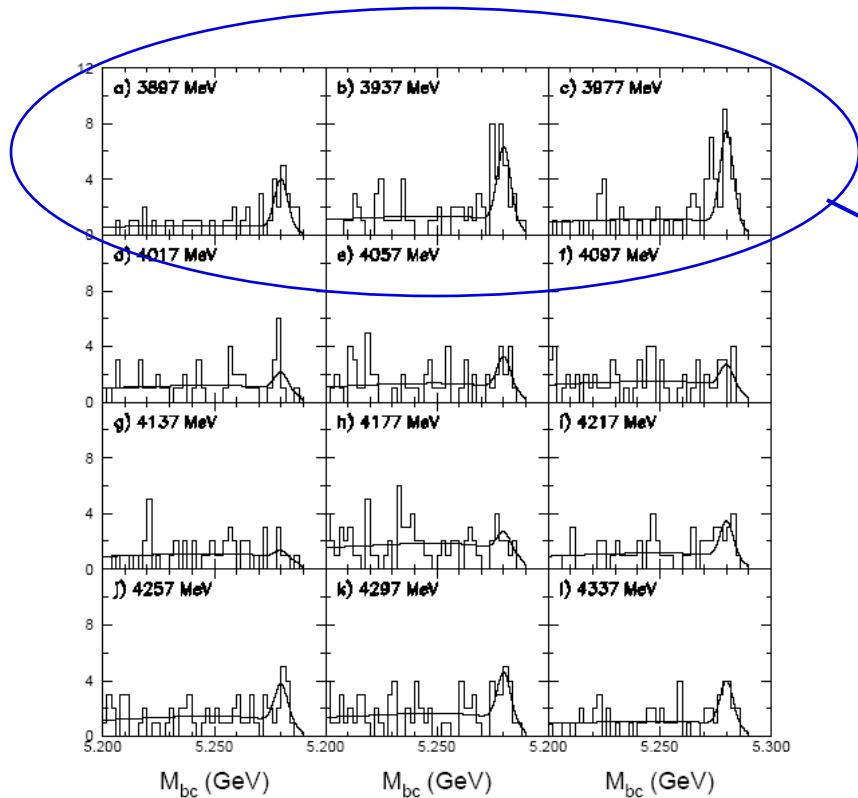

$M_{bc}$  for each  $M_{J/\psi\omega}$  bin

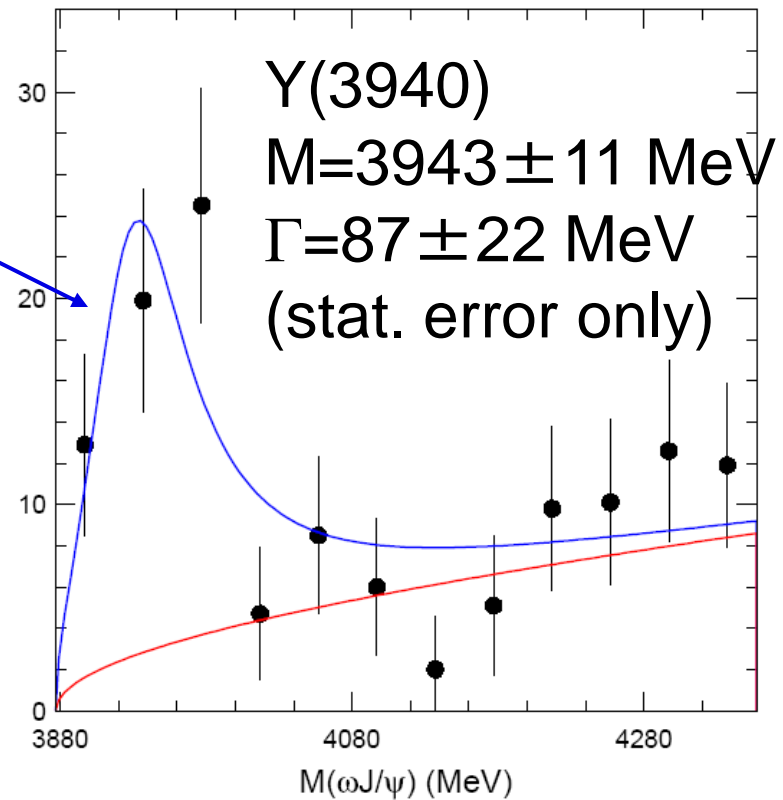

B signal yield as a func. of  $M_{J/\psi\omega}$

Belle, 275M  $B\bar{B}$ , PRL94,182002(2005)

# $X(3872) \rightarrow J/\psi \omega$

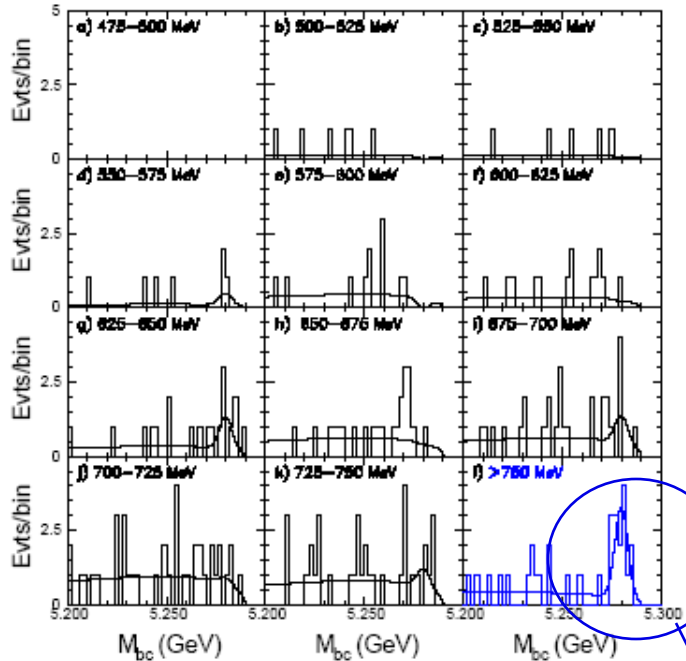

$M_{bc}$  in each  $M_{J/\psi\omega}$  bin

$12.4 \pm 4.2$  events

Belle 275M  $B\bar{B}$ ,  
hep-ex/0505037

A virtual  $\omega$ ?

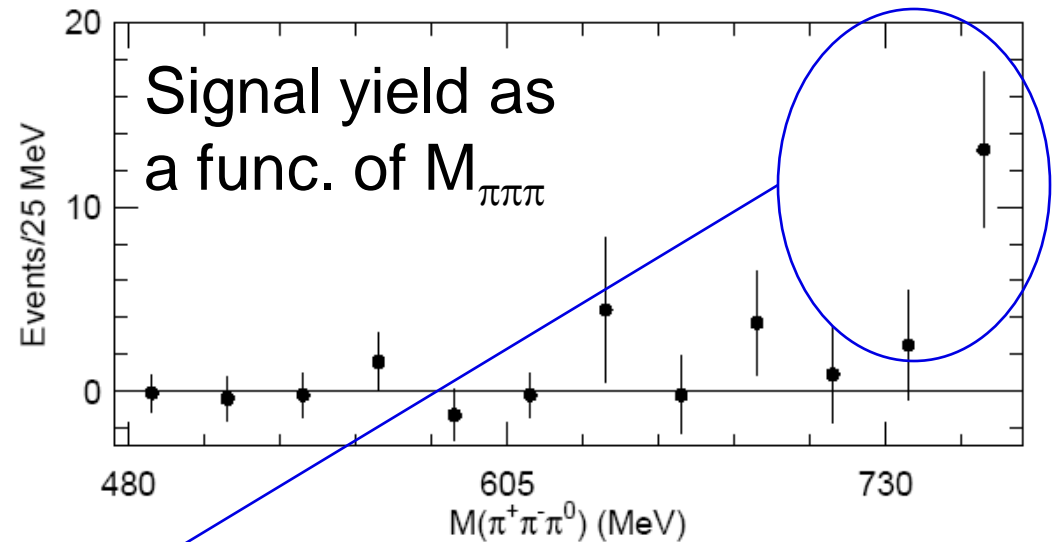

Signal yield as  
a func. of  $M_{\pi^+\pi^-\pi^0}$

$$\frac{\text{Br}(X \rightarrow 3\pi J/\psi)}{\text{Br}(X \rightarrow 2\pi J/\psi)} = 1.0 \pm 0.5$$

Large isospin (at least G-parity)  
violation!!

# $X(3872) \rightarrow J/\psi \gamma$

$B \rightarrow K \gamma J/\psi$   
candidates

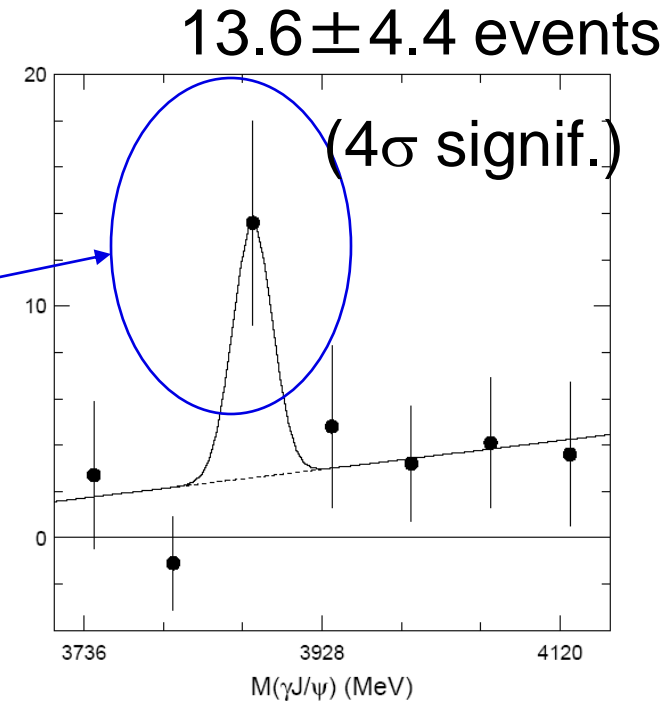
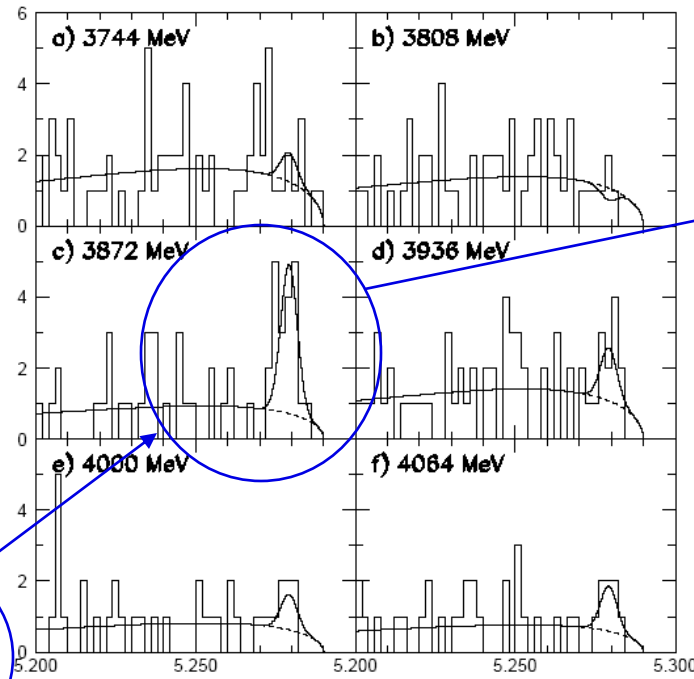
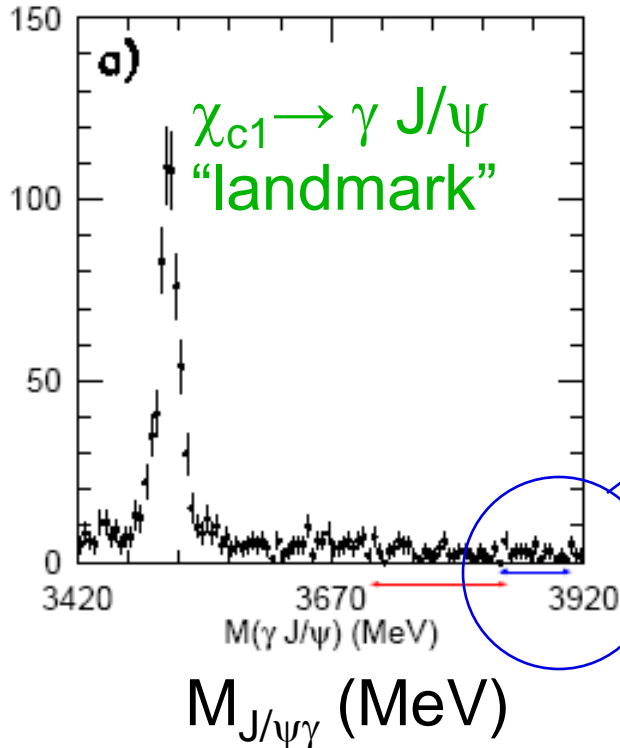

B signal yield as  
a func. of  $M_{J/\psi\gamma}$

$$\frac{\text{Br}(X \rightarrow \gamma J/\psi)}{\text{Br}(X \rightarrow \pi\pi J/\psi)} = 0.14 \pm 0.05$$

Belle 275M  $\overline{B}B$   
hep-ex/0505037

# X(3872)'s $J^{PC}$

**C=+1 is established!**

- X(3872)  $\rightarrow$  J/ $\psi$   $\gamma$  is only allowed for C=+1.
- X(3872)  $\rightarrow$  J/ $\psi$   $\omega$  supports this picture.
- X(3872)  $\rightarrow$  J/ $\psi$   $\pi\pi$ ,  $M_{\pi\pi}$  looks like a  $\rho$ .

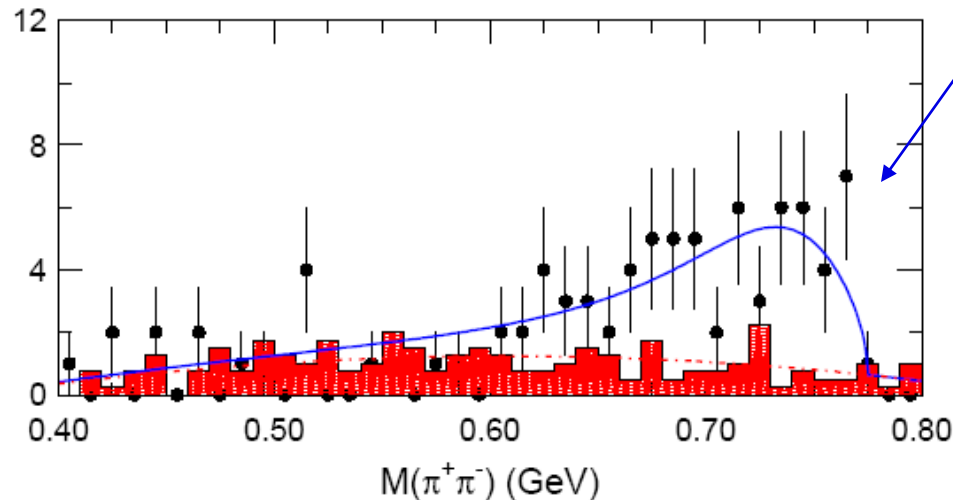

Shape of  $M_{\pi\pi}$  distribution favors S-wave btw J/ $\psi$  and  $\rho$  (different centrifugal barrier for P, D-wave)  $\rightarrow$  **P=+1!**

# $X(3872)$ 's $J^{PC}$ (cont.)

Angular distribution of  $X(3872)$ 's decay products  
→ determination of spin.

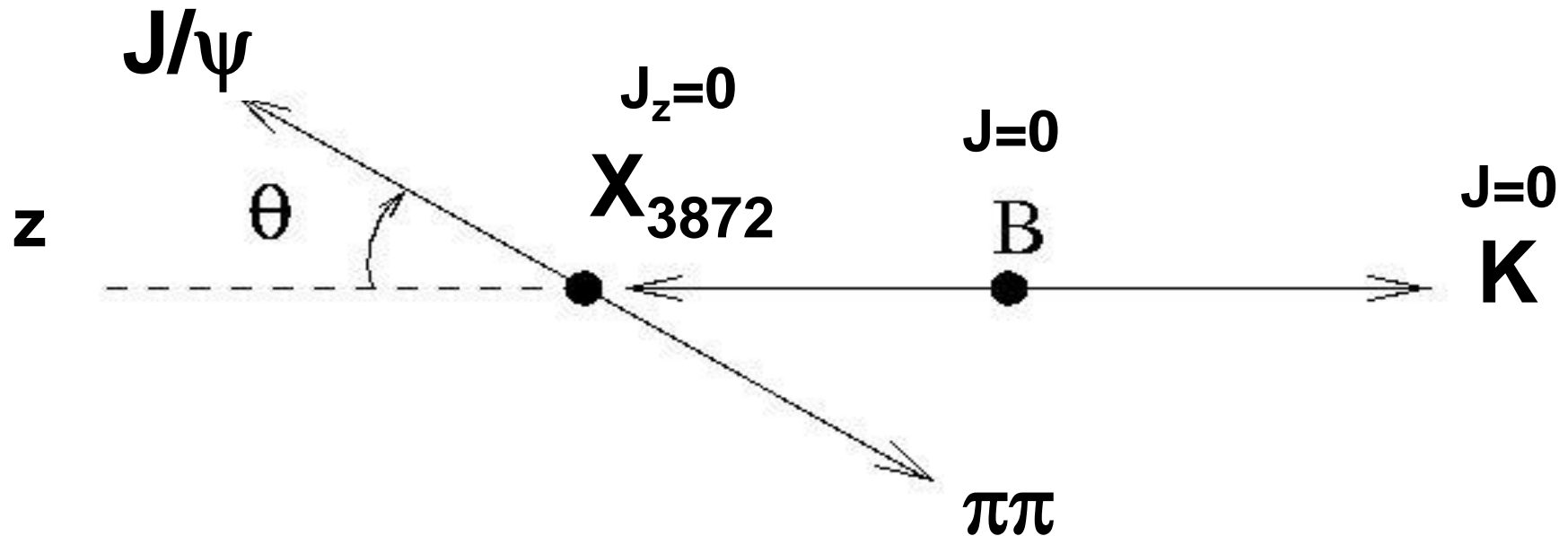

Rosner, PRD70,094023, Bugg, PRD71,016006,

Suzuki&Pakvasa, PLB579,67

# Let's test $0^{++}$ hypothesis.

In the limit where  $X(3872)$ ,  $\pi\pi$ , &  $J/\psi$  rest frames coincide:

$$dN/d\cos\theta_{l\pi} \propto \sin^2\theta_{l\pi}$$

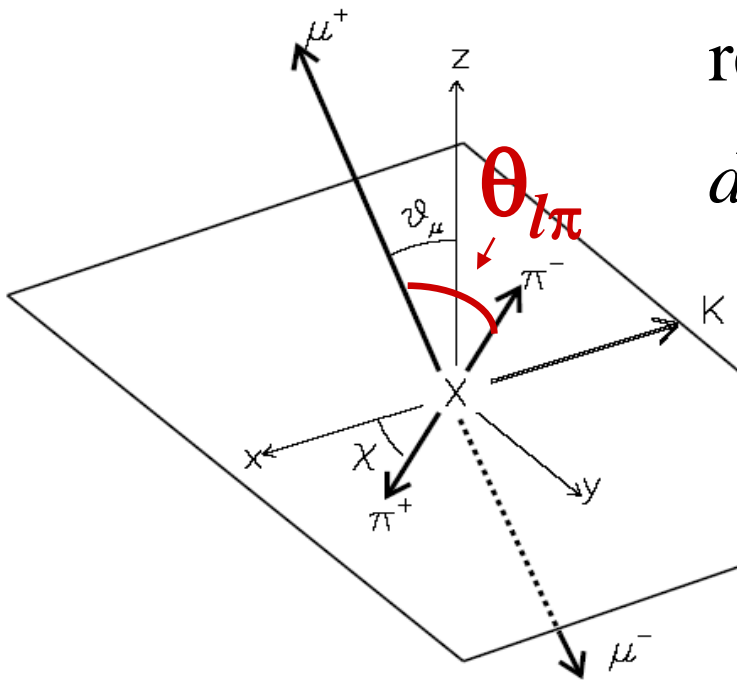

Rule out  $0^{++}$ !

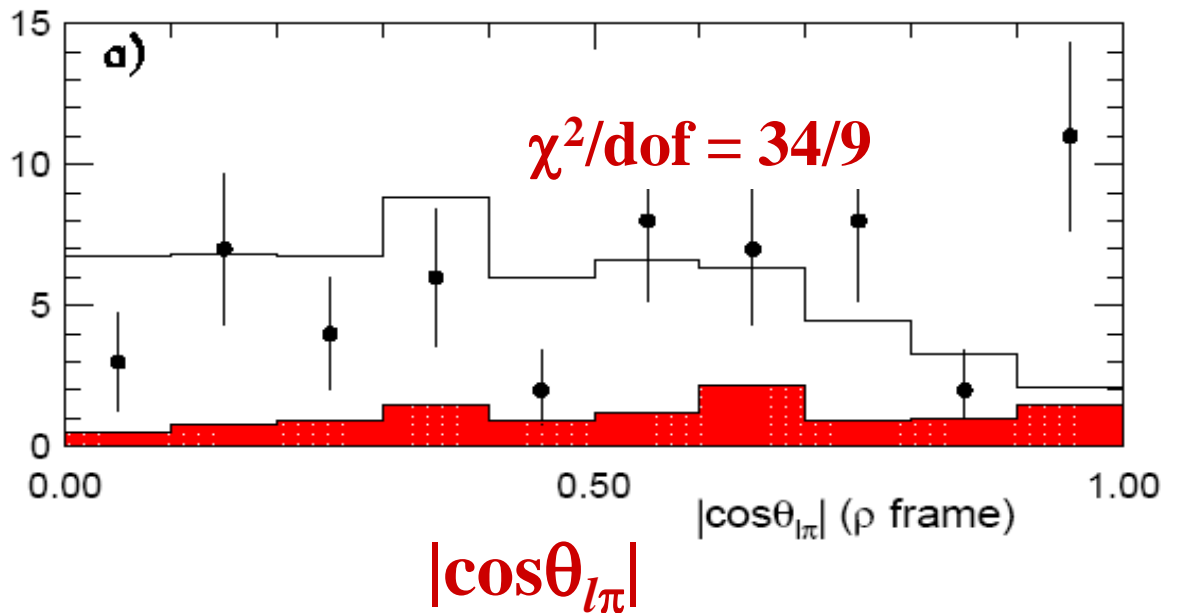

$|\cos\theta_{l\pi}|$

# How about $1^{++}$ ?

$$dN/d\cos\theta d\cos\chi \propto \sin^2\theta_l \sin^2\chi$$

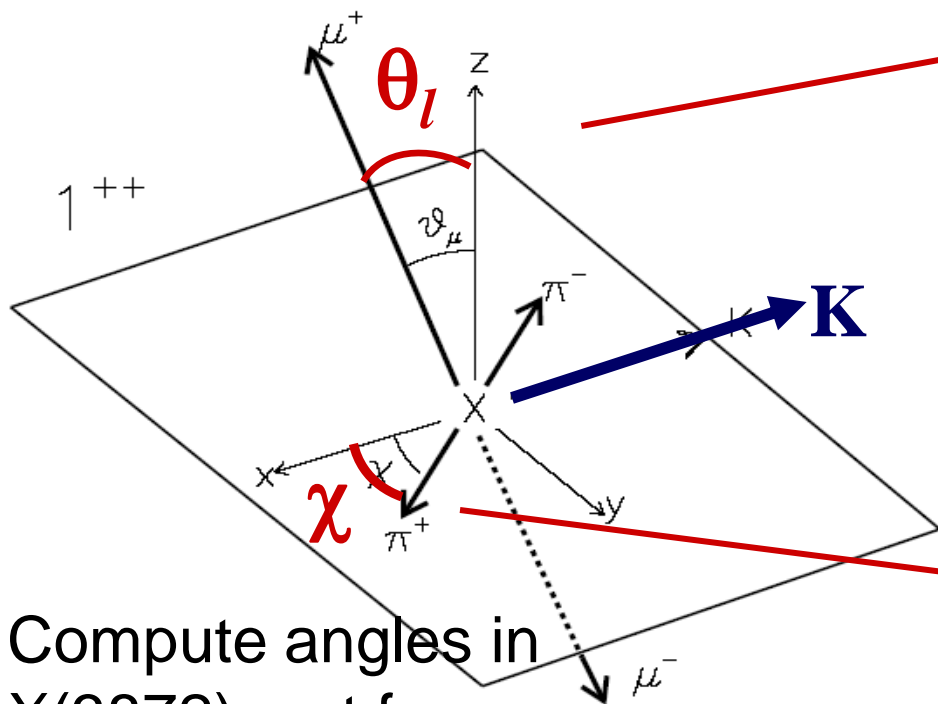

Compute angles in  $X(3872)$  rest frame.

$1^{++}$  looks OK!

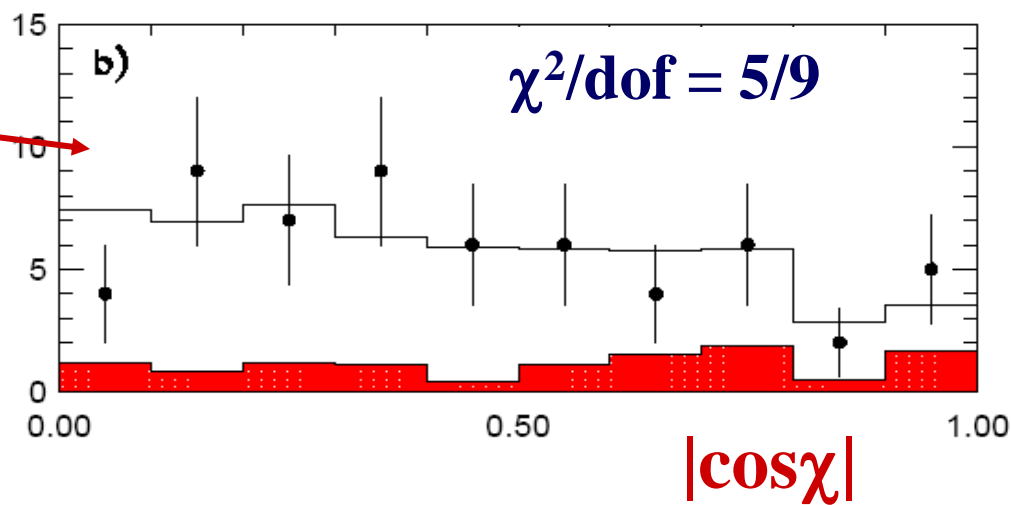
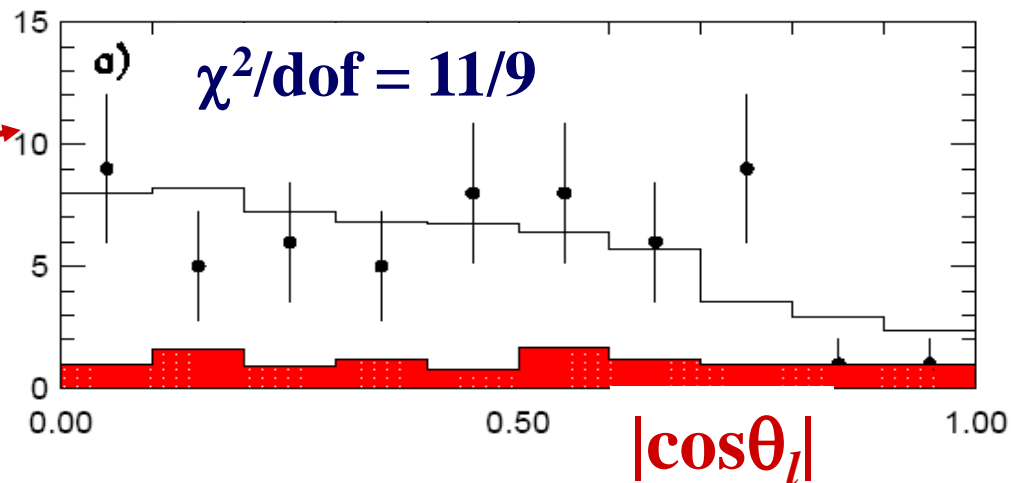

# Look $B \rightarrow K D^0 \bar{D}^0 \pi^0$ candidates

$$D^{*0} \rightarrow D^0 \pi^0?$$

PRL 97, 162002 (2006)

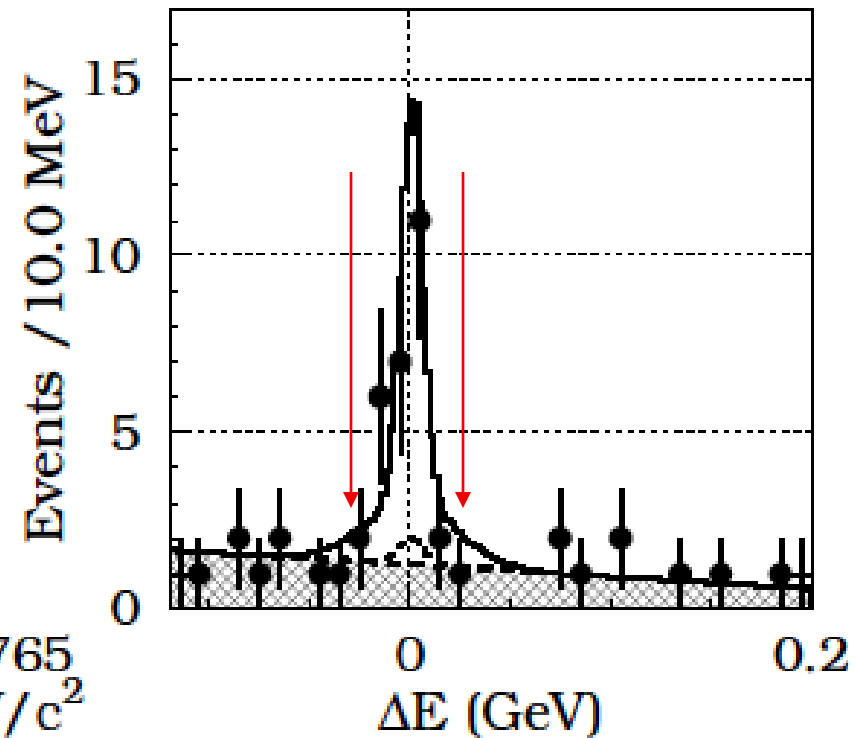
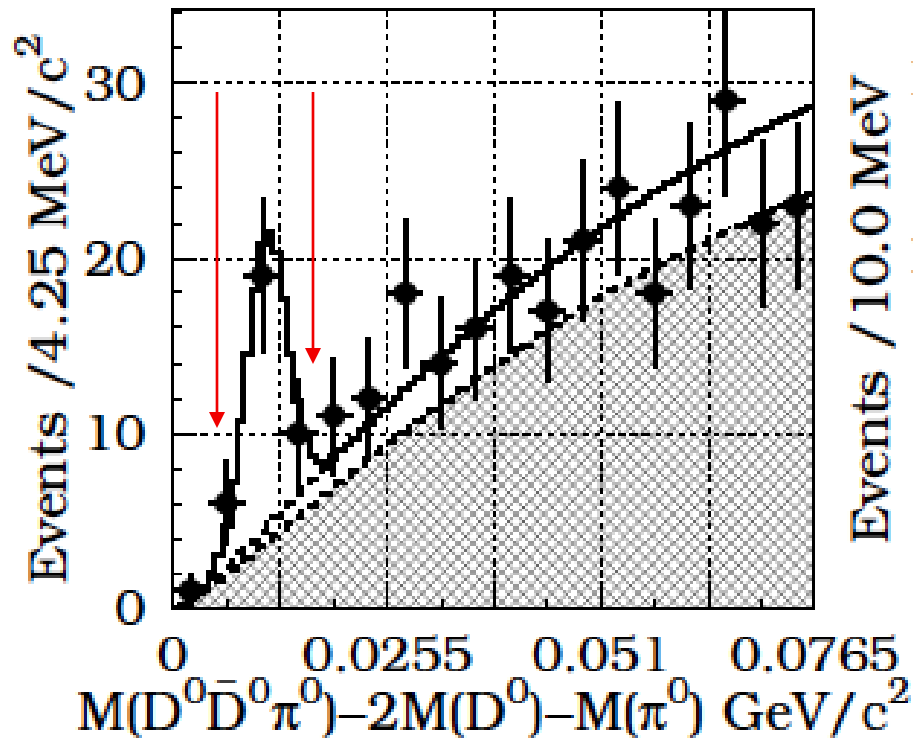

$M_{DD\pi} = 3875.4 \pm 0.7 + 0.4 / -1.7 \pm 0.9$  MeV  
Significance of the excess is  $6.4\sigma$ .

**Rule out  $2^{++}$  !**  
(Strong threshold suppression.)

# Properties of $X(3872)$ ; what is it?

$$J^{PC}=1^{++}.$$

That means  $\chi_{c1}$  if it is usual charmonium, but

- Mass is 100MeV off from the prediction.
- Small  $\Gamma(J/\psi \gamma) / \Gamma(J/\psi \pi\pi)$  disfavors this hypothesis.

→ not likely to be  $\chi_{c1}$ !

$D\bar{D}^*$  bound state?

- $J^{PC}=1^{++}$  is favored.
- Isospin violation is predicted
- $\Gamma(J/\psi \gamma) < \Gamma(J/\psi \pi\pi)$  is also predicted.

→ looks consistent with expectations.

- Where is the partner??

# Y(3940)=X(3945); what is it?

No obvious charmonium assignment.

Is it a  $c\bar{c}g$  hybrid?

- Predicted by QCD,
- Decays to  $\bar{D}D$  and  $\bar{D}D^*$  are suppressed  
(“open-charm” thresh =  $m_D + m_{D^{**}} = 4.3$  GeV)
- large *hadron*+ $J/\psi$  widths are predicted
- masses expected to be 4.3 ~ 4.4 GeV  
(higher than what we see)

→ Need more study

# Double charmonium production

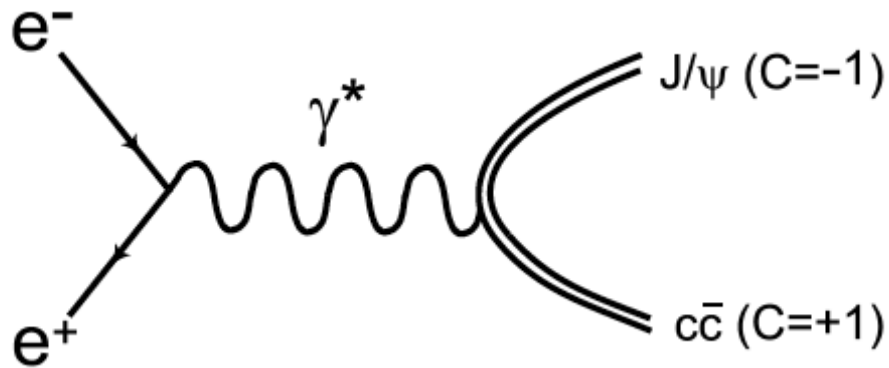

The  $e^+e^-$  annihilation can become **double charmonium**.  
Photon has  $C=-1$ , if one of them is tagged as  $J/\psi$ , other  
must be  $C=+1$  charmonium.

# Look recoil mass spectrum

$$M_{\text{rec}}^2 = \{(E_{ee}, \vec{P}_{ee}) - (E_{J/\psi}, \vec{P}_{J/\psi})\}^2$$

In the recoil mass spectrum, there is a peak at 3490 MeV!

No decay to  $J/\psi \omega$ , but  $DD^*$ .

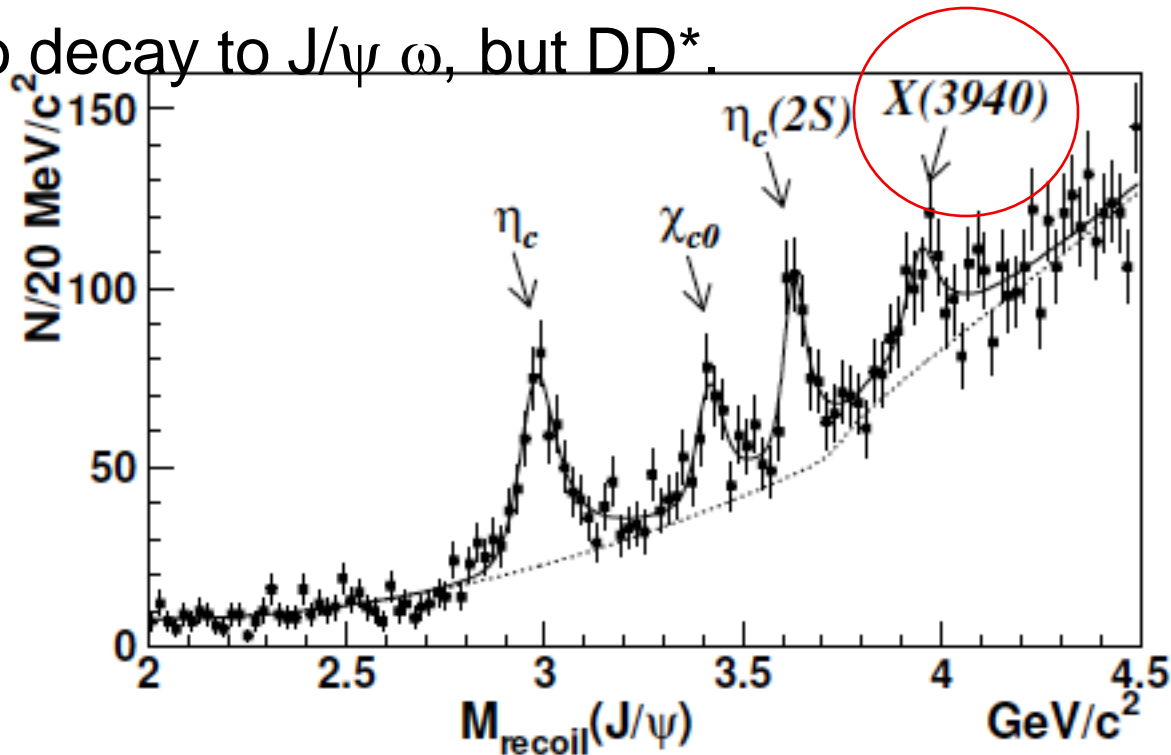

PRL 98, 082001 (2007)

$$Z(3930) = \chi_{c2}(2P)$$

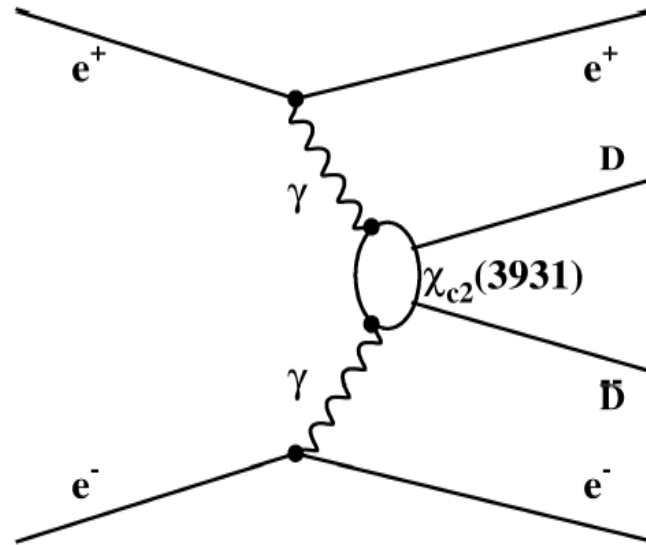

Two photon collision is a good source of  $J=0$  and  $J=2$  mesons.

Reconstruct DD, require small  $P_t$  w.r.t initial  $e^+e^-$  beams.  
(In order to select quasi-real photon collisions)

# $Z(3930) = \chi_{c2}(2P)$

PRL 96, 082003 (2006)

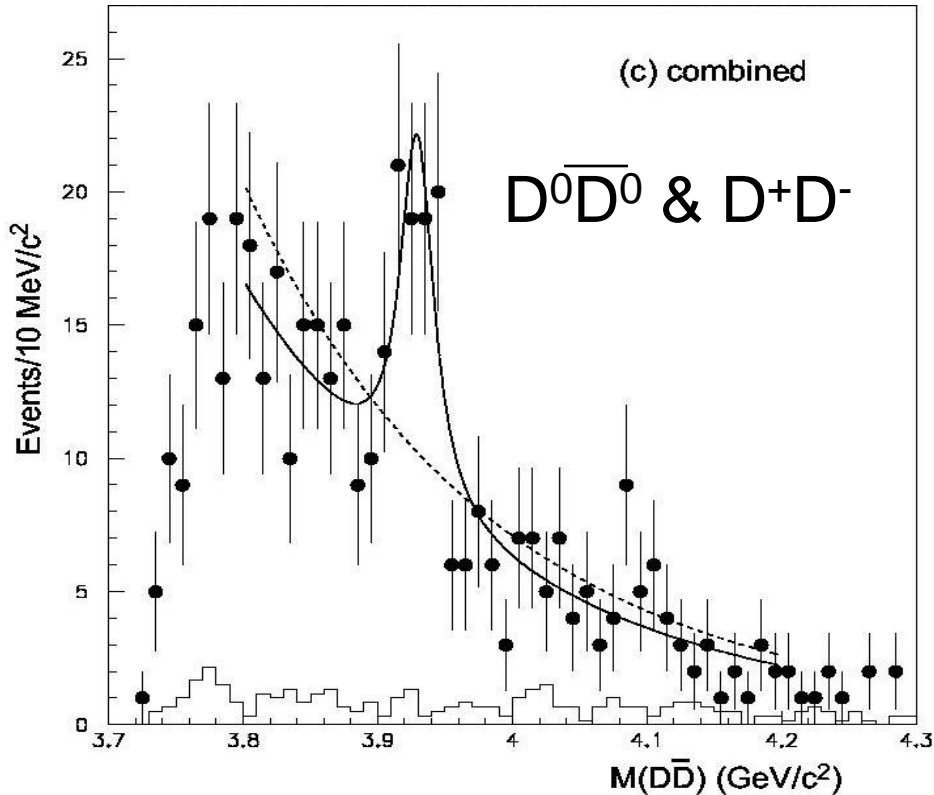

$64 \pm 18$  events ( $5.3 \sigma$ )

$M = 3929 \pm 5 \pm 2$  MeV

$\Gamma = 29 \pm 10 \pm 2$  MeV

Angular distribution  
matched well  
 $\chi_{c2}(2P)$  prediction.

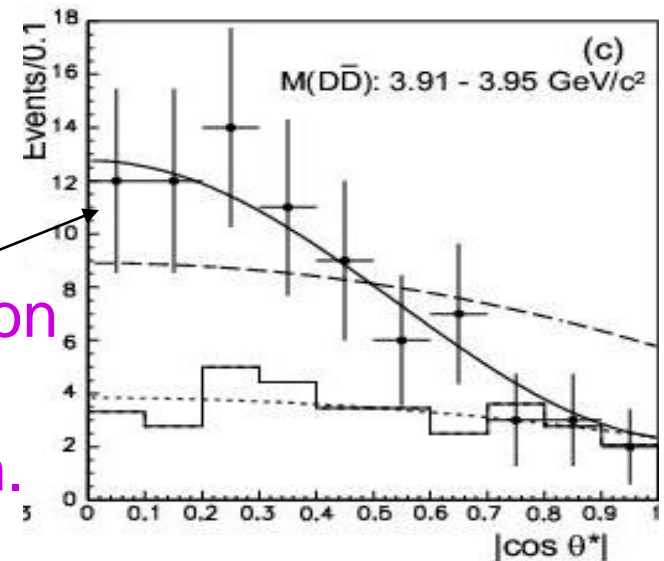
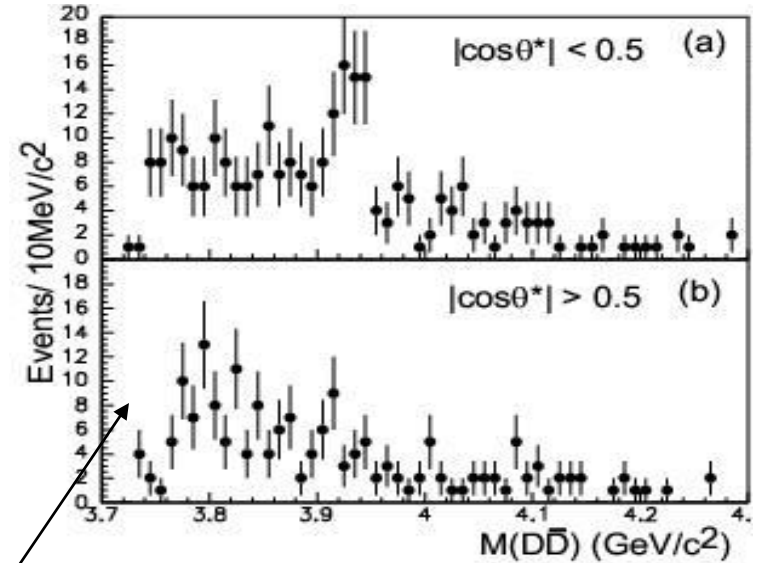

# B → double charmed meson

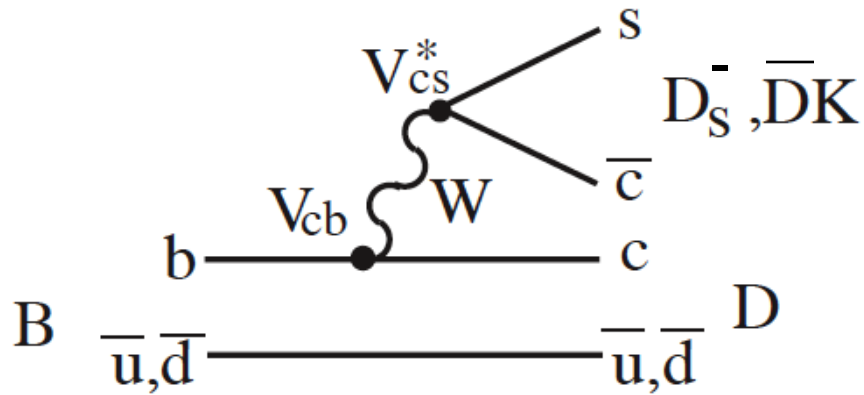

Observations of  $D_{S_J}(2317)$  and  $D_{S_J}(2457)$  mesons were done in  $B \rightarrow D_{S_J} D$  decay.

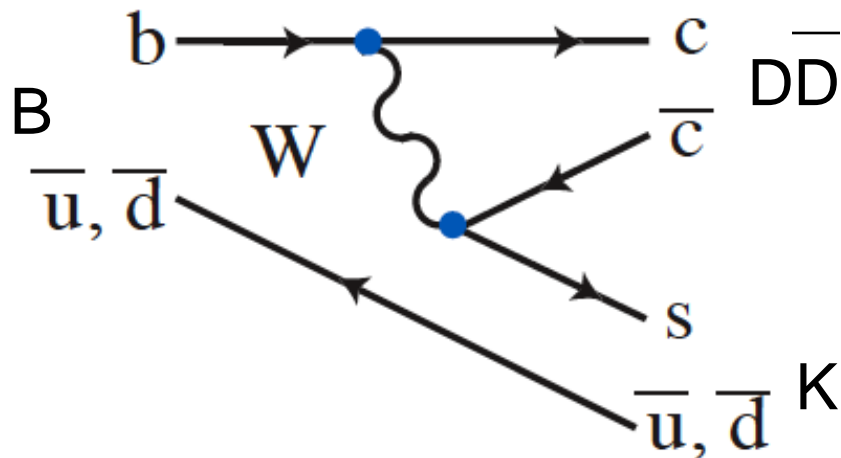

While,  $B \rightarrow D\bar{D}K$ , both color-favored and color-suppressed diagrams contribute.

# $D_{SJ}(2700)$

hep-ex/0608031

Reconstruct  $B^+ \rightarrow \bar{D}^0 D^0 K^+$  candidates, look Dalitz distribution.

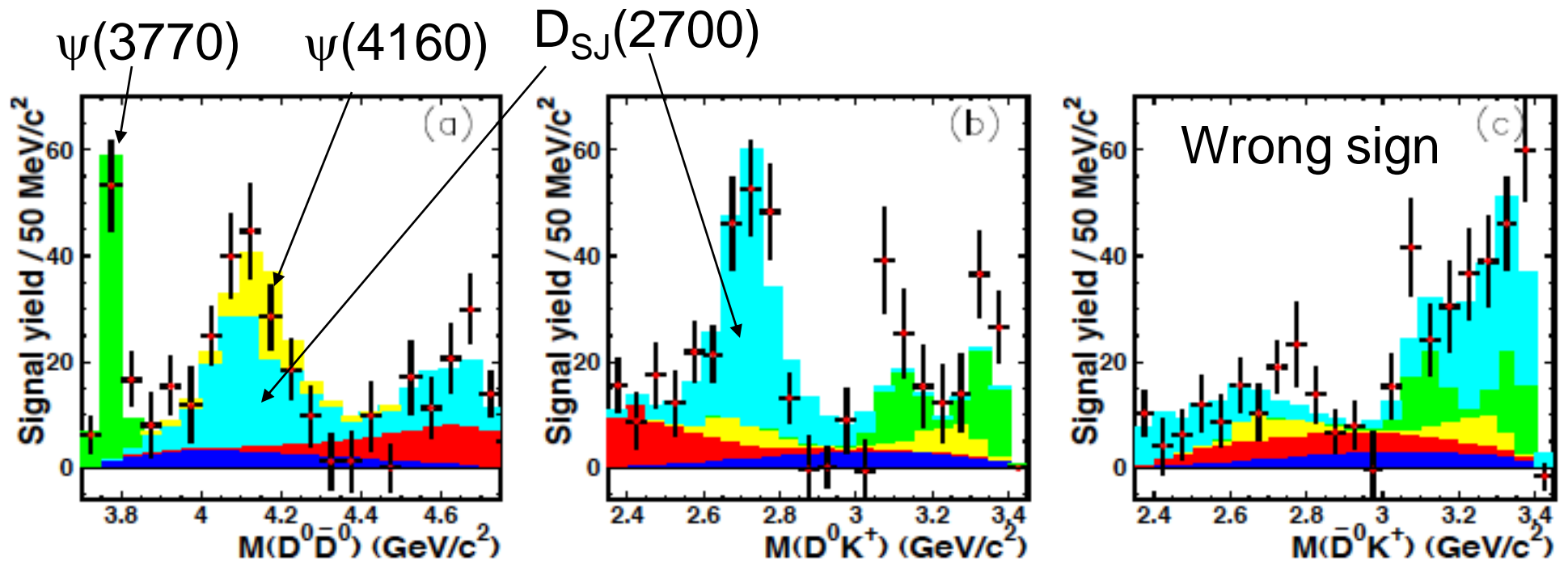

$$M = 2715 \pm 11_{-14}^{+11} \text{ MeV}/c^2 \quad \Gamma = 115 \pm 20_{-32}^{+36} \text{ MeV}/c^2$$

$J^P=1^-$ , Potential model prediction is  $M=2721 \pm 10 \text{ MeV}$

# $\Lambda(2880)^+$

From  $e^+e^- \rightarrow cc$ , select  $\Sigma_c(2445) \pi$

PRL 98, 262001 (2007)

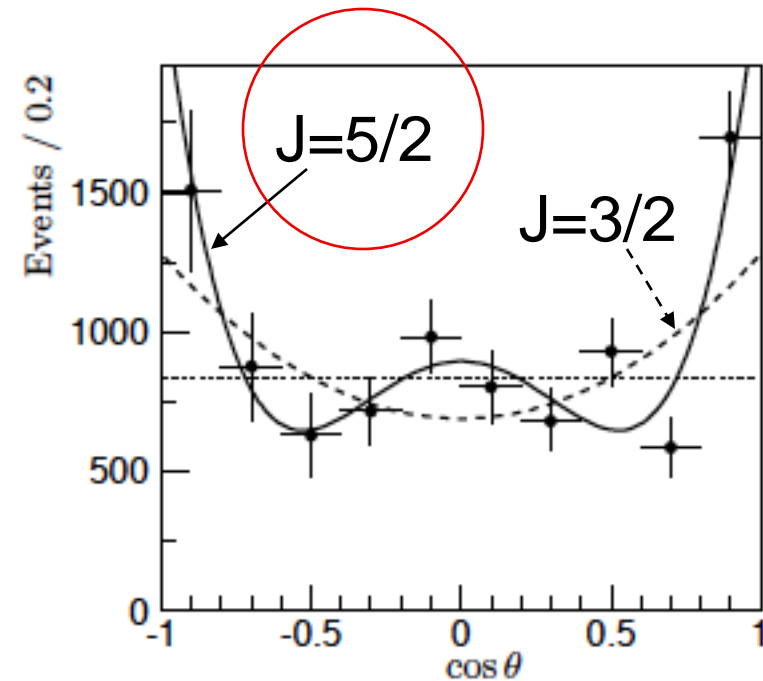
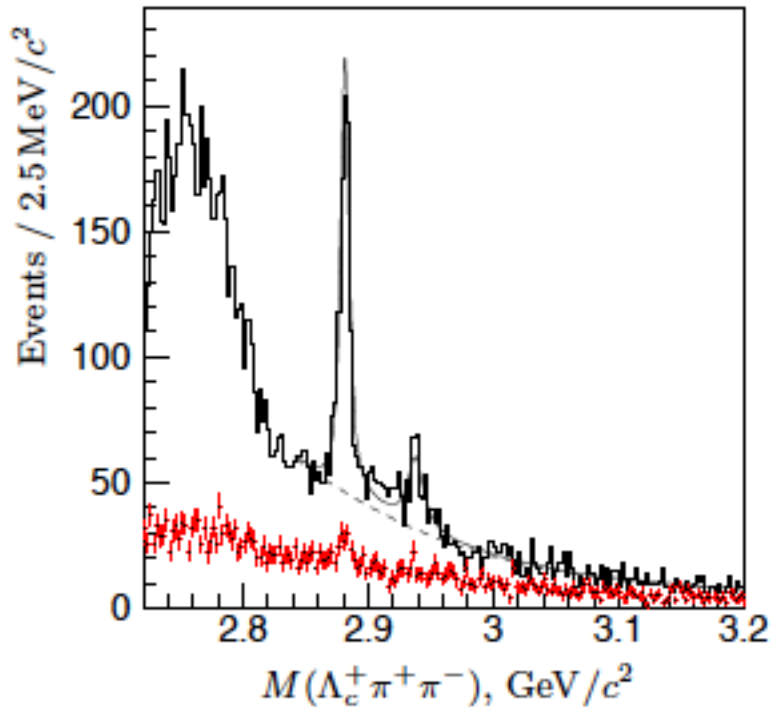

pion angular distribution

$R \equiv \frac{\Gamma(\Sigma_c(2520)\pi)}{\Gamma(\Sigma_c(2455)\pi)}$  is small,  $0.225 \pm 0.062 \pm 0.025 \rightarrow$  P-odd.

# Recent news on accelerator

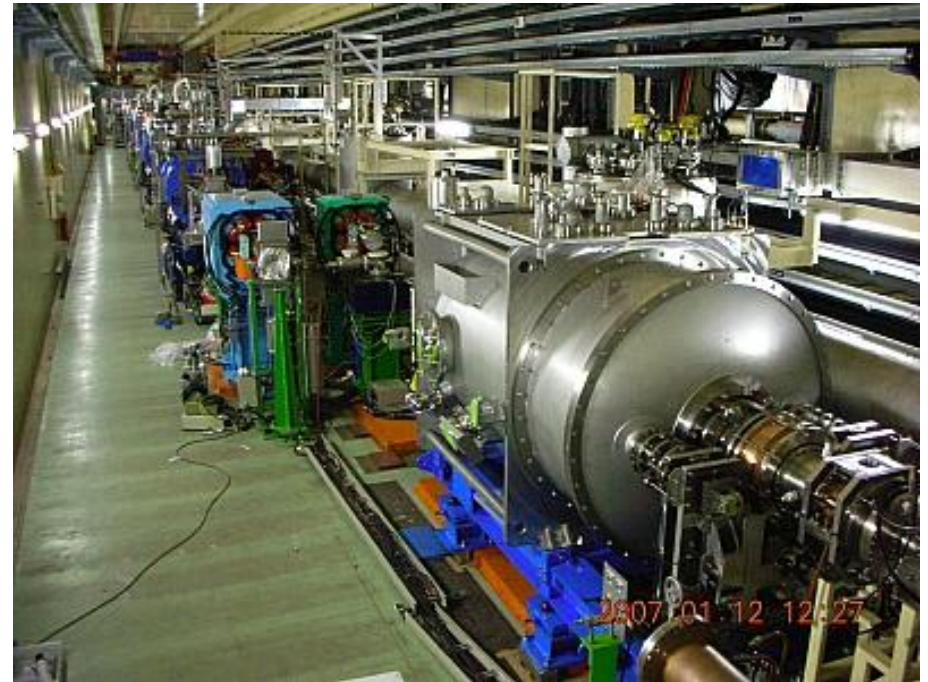
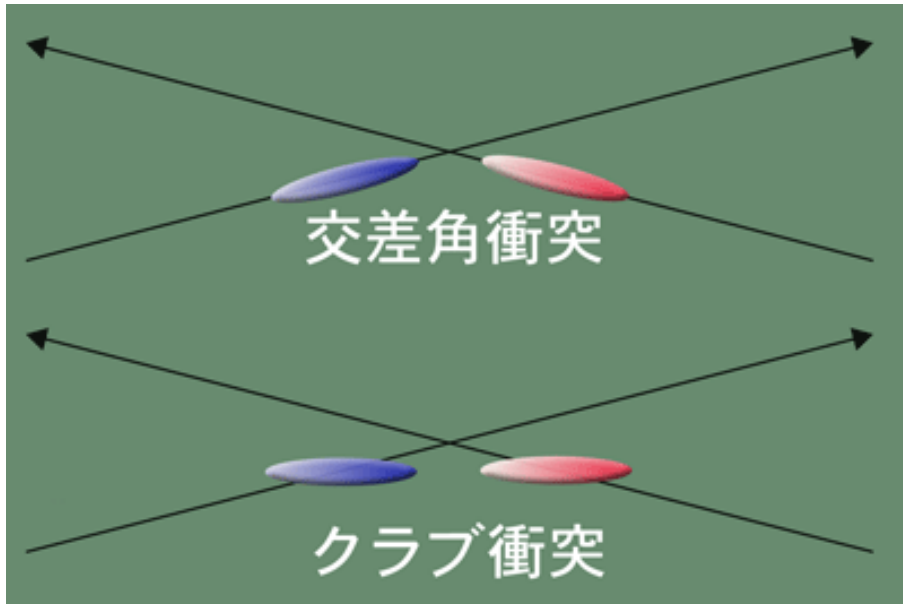

Crab crossing ... larger beam-beam parameter for higher luminosity.  
Recently  $10^{34} \text{ cm}^{-2} \text{ s}^{-1}$  has been achieved with  $I_{\text{LER}}=1.3\text{A}$ ,  $I_{\text{HER}}=0.7\text{A}$ !  
→ Good News!

# Future prospect

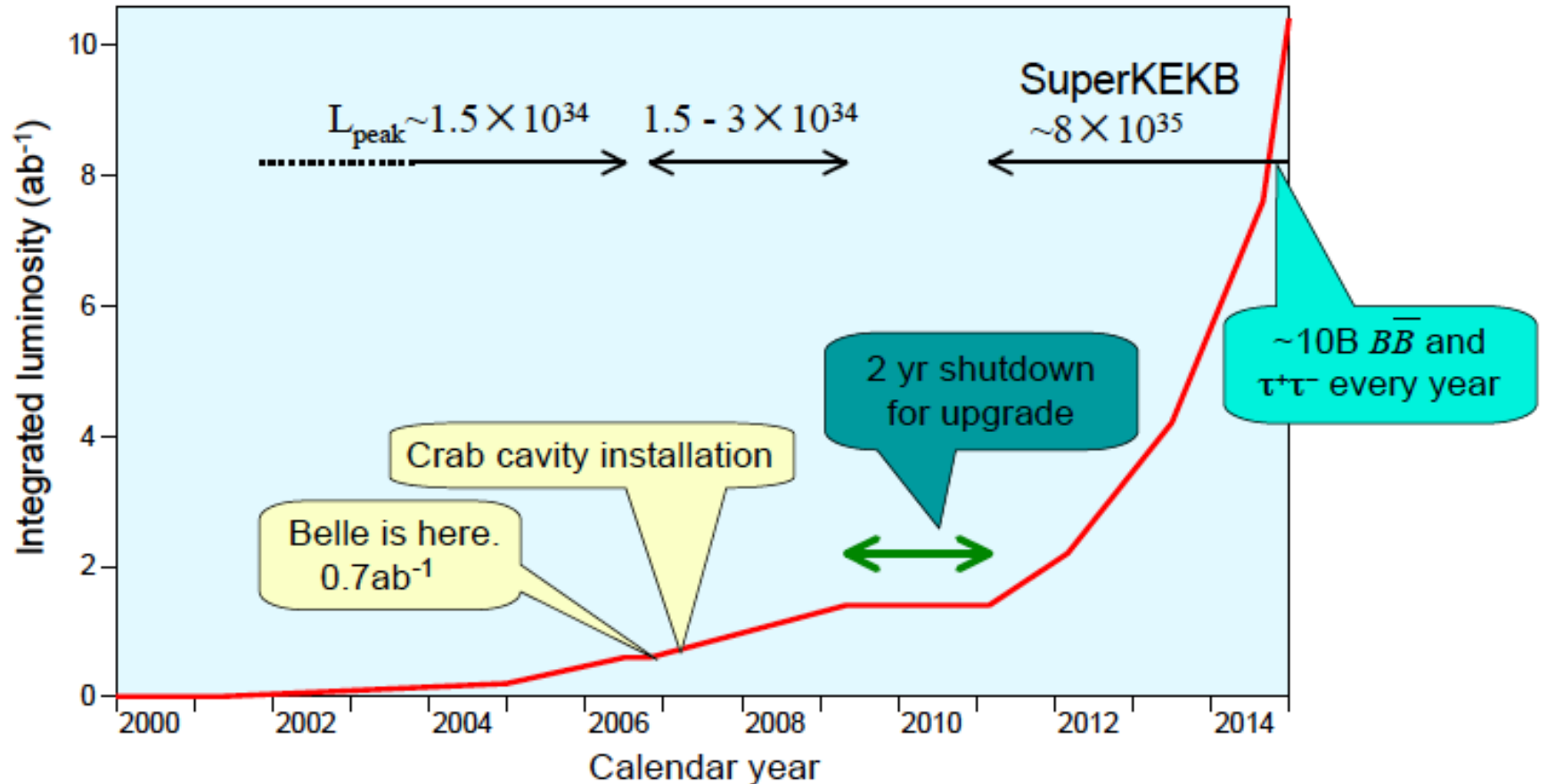

Not only New CPV measurements but also rich data sample to find something NEW in SPECTROSCOPY!

# Future prospect (cont.)

## Upgraded Components for SuperKEKB

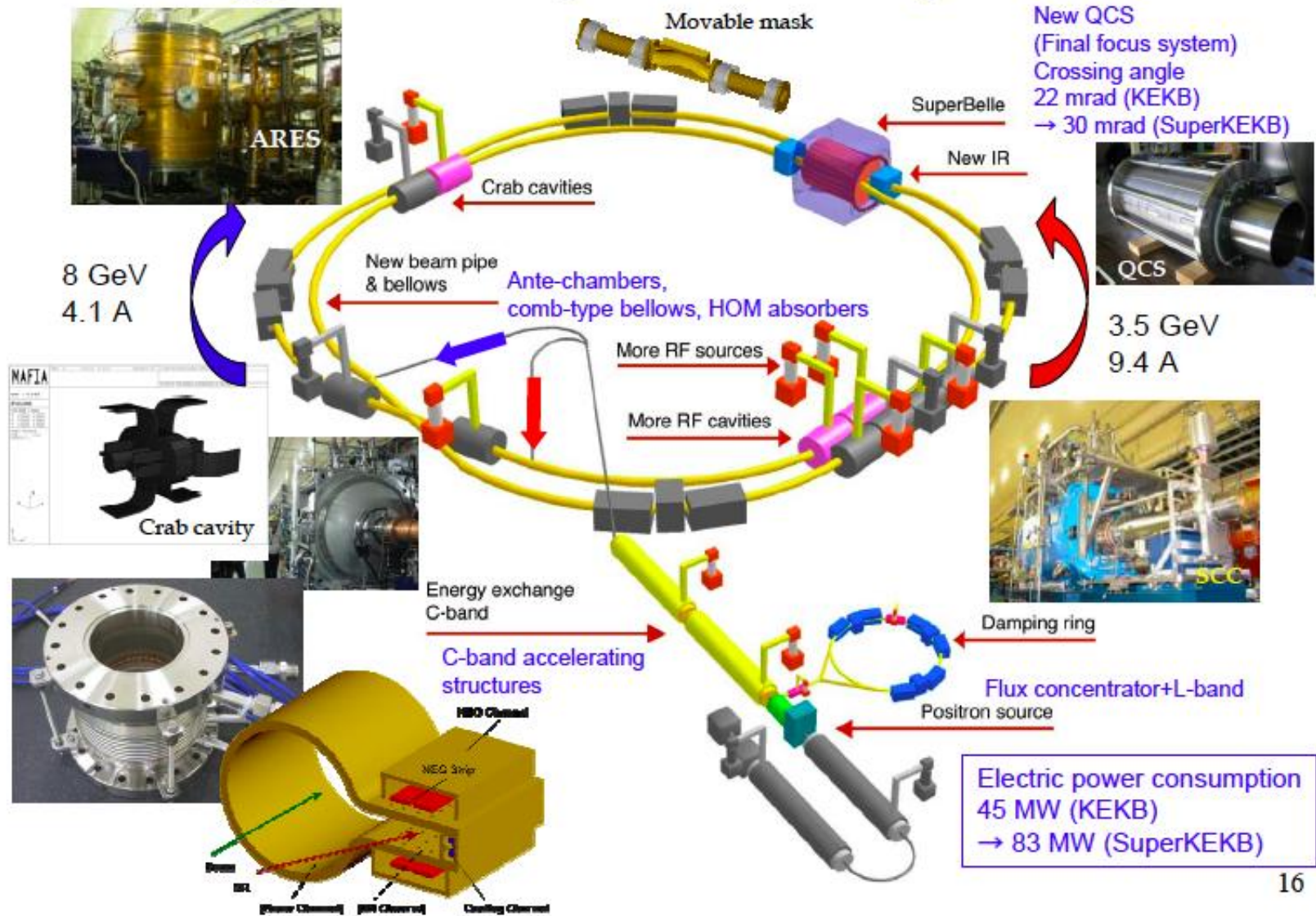

# Summary

- Charmonium(-like) and charm hadrons have been discovered/investigated by various sources.
  - $X(3872)$ ,  $Y(3940)=X(3945)$ ,  $D_{Sj}$  in B decays
  - $X(3940)$  in double charmonium production
  - $Z(3930)=\chi_{c2}(2P)$  in two photon collision
  - Charmed baryons in  $e^+e^- \rightarrow cc$  continuum
- They are the bonus given by highest luminosity
- Hopefully such situation continues in Super B-factory.

# Summary

## X(3872)

- $J^{PC}=1^{++}$  established, properties consistent with a  $\overline{DD}^*$  bound state.
- Where is the partners??

## Y(3940)

- No obvious charmonium assignment, might be a ccg hybrid.
- Need more study to have conclusive picture.

The studies shown today are based on  $275\overline{M}$  BB, while  $660\overline{M}$  BB have been accumulated by 2005 summer.

→ following would appear soon,

- More precise measurements of their properties.
- Attempts to hunt for something new.

Back up slides

Example:  $1^{--}$

Use  $B \rightarrow K \psi'$

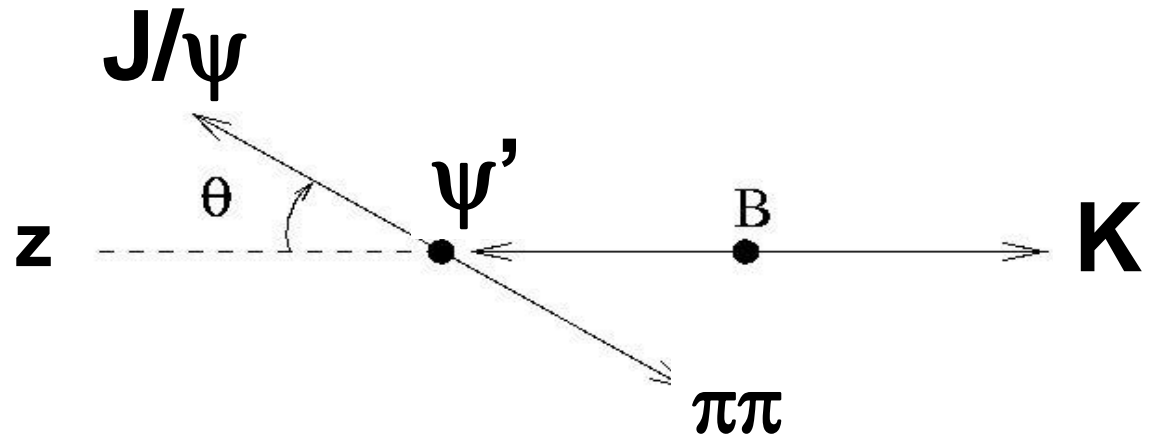

$$dN/d\cos\theta \propto \sin^2\theta_{K\mu}$$

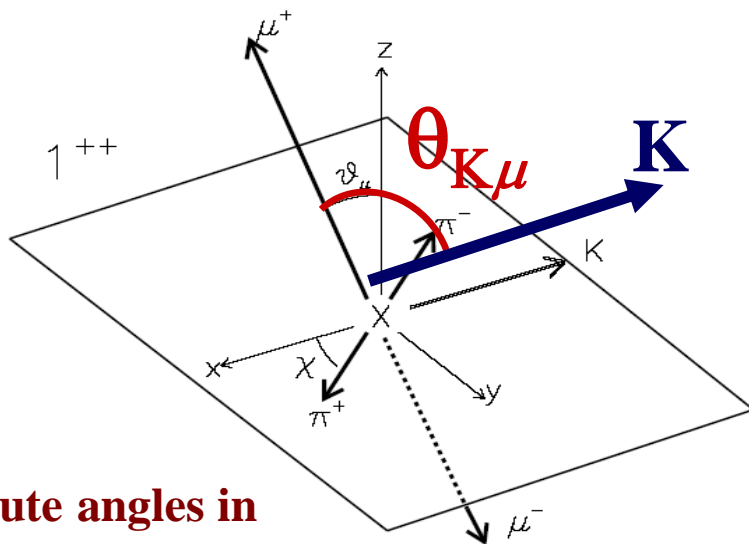

compute angles in  
 $J/\psi$  restframe

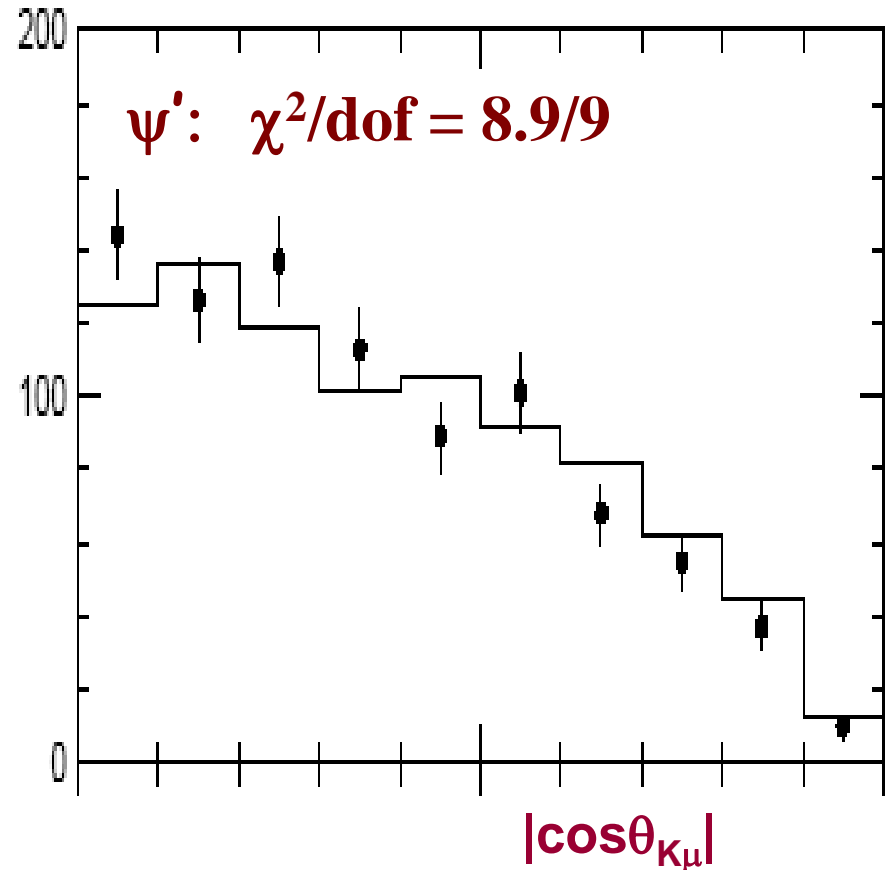

# $|\cos\theta_{K^0}|$ for X(3872) events

$\chi^2/dof = 45/9$  fit with  $1^{--}MC + bkgd$

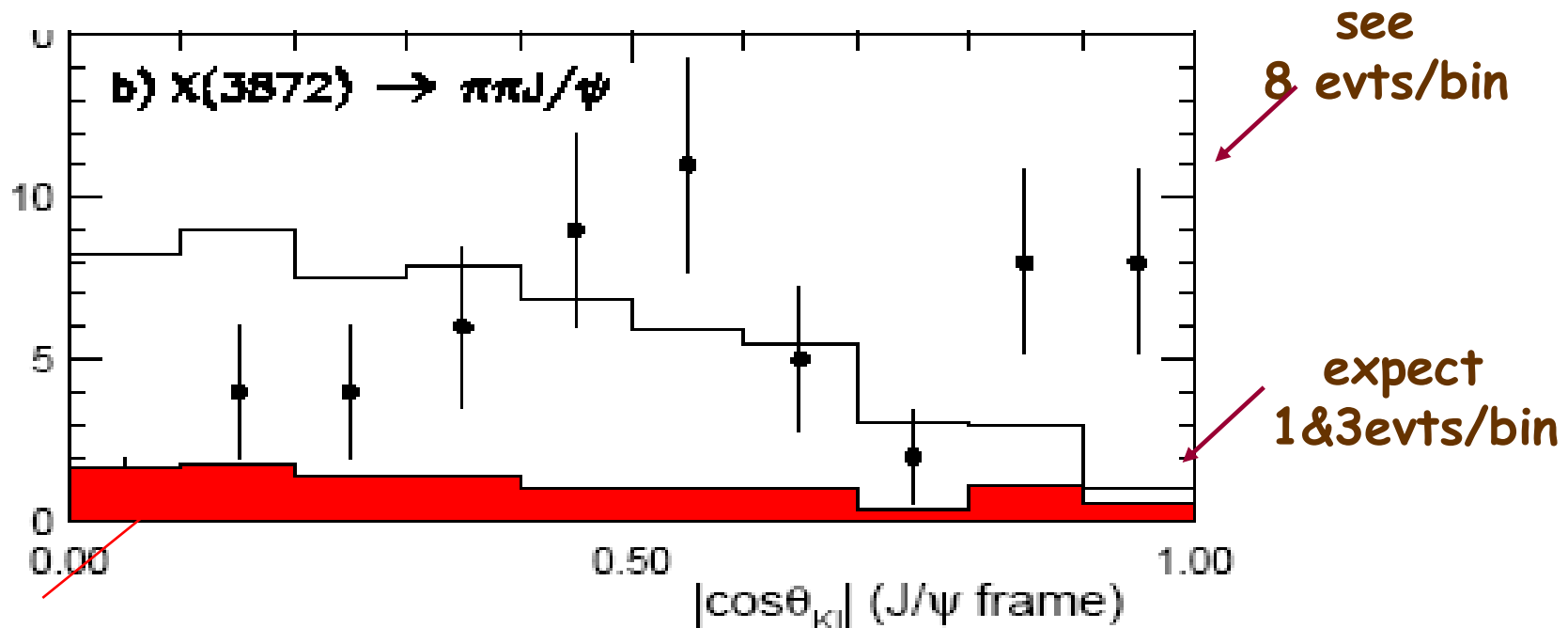

background scaled from sidebands

**X(3872) is not  $1^{--}$  !**

$0^{-+}$

$$M \propto \vec{p}_{J/\psi} \cdot (\vec{\varepsilon}_{J/\psi} \times \vec{\varepsilon}_\rho)$$

$0^{-+} : \sin^2\theta \sin^2\psi$

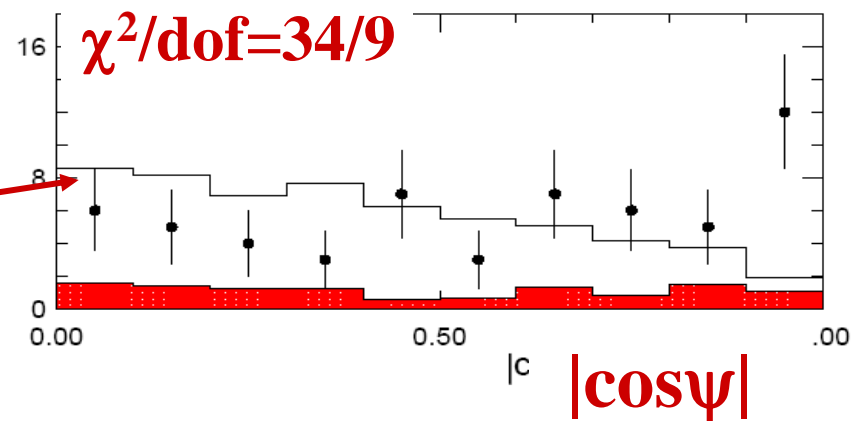
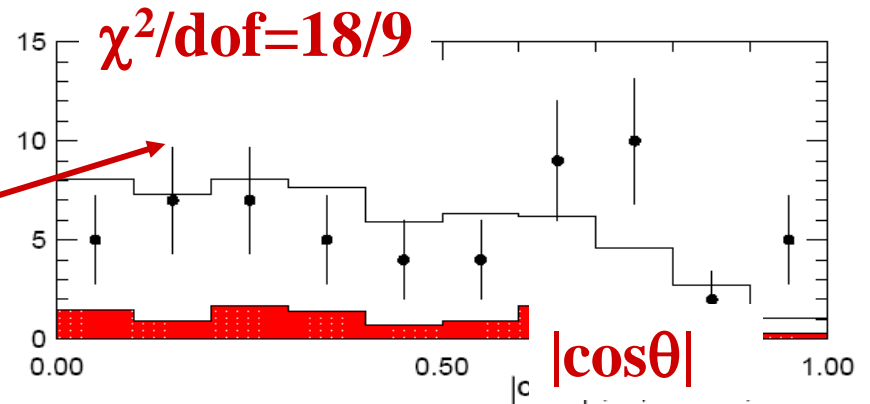
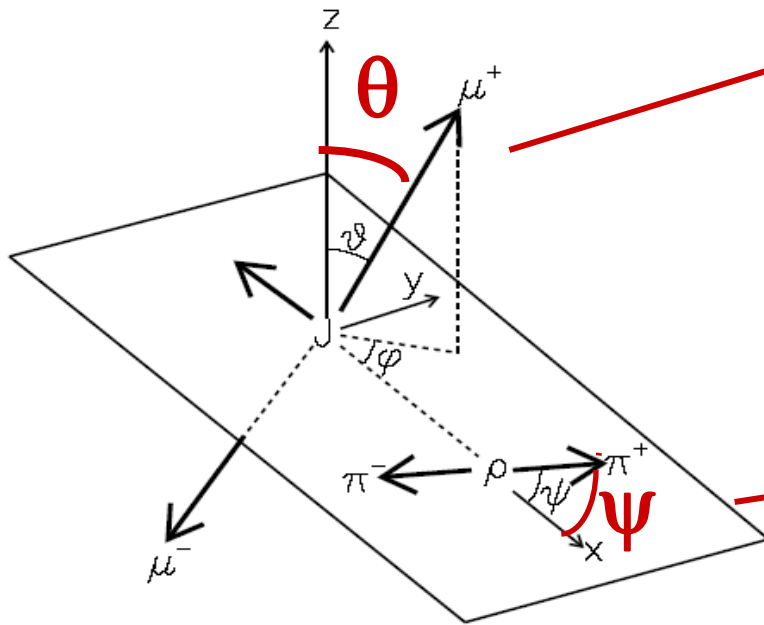

safe to rule out  $0^{-+}$

# $M(\gamma J/\psi)$ look-back plot

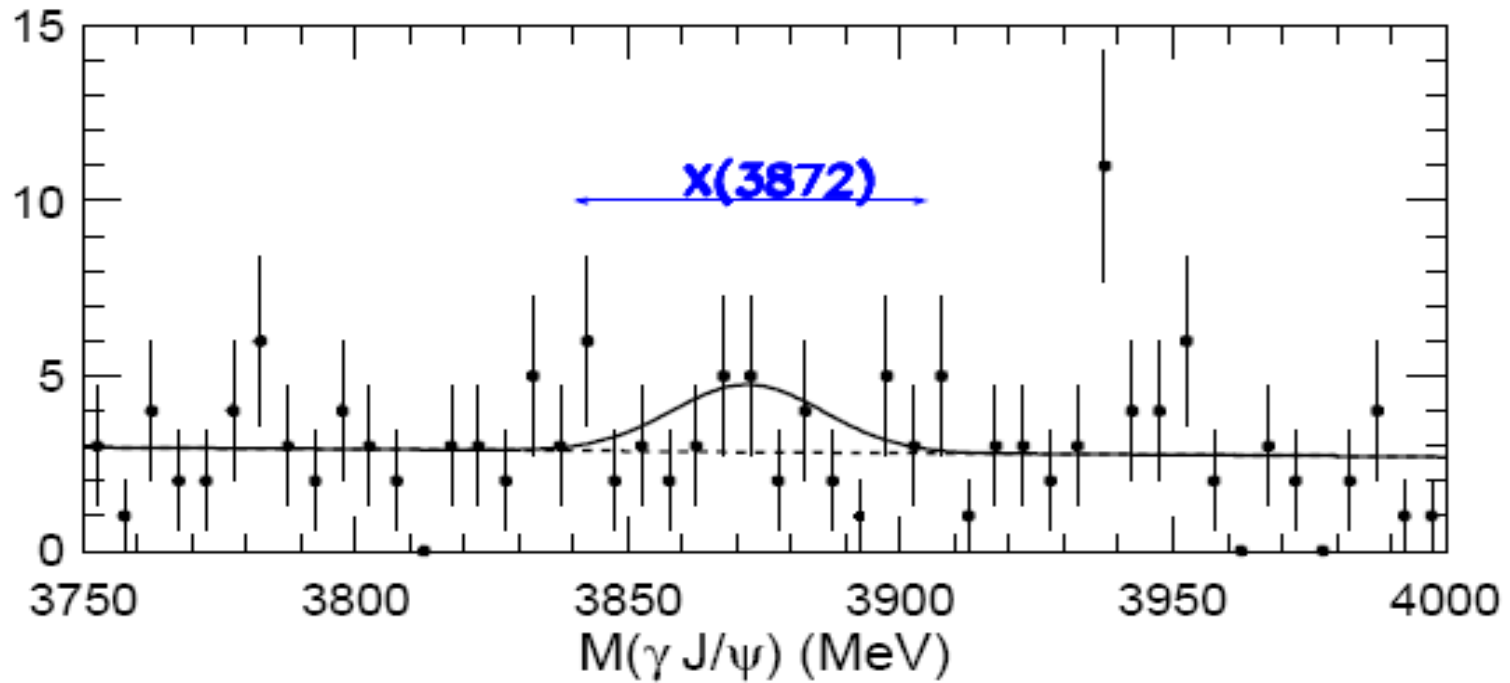

# $M(\pi\pi)$ can distinguish $\rho$ - $J/\psi$ S- & P-waves

S-wave:  $\chi^2/\text{dof} = 43/39$

(CL= 28%)

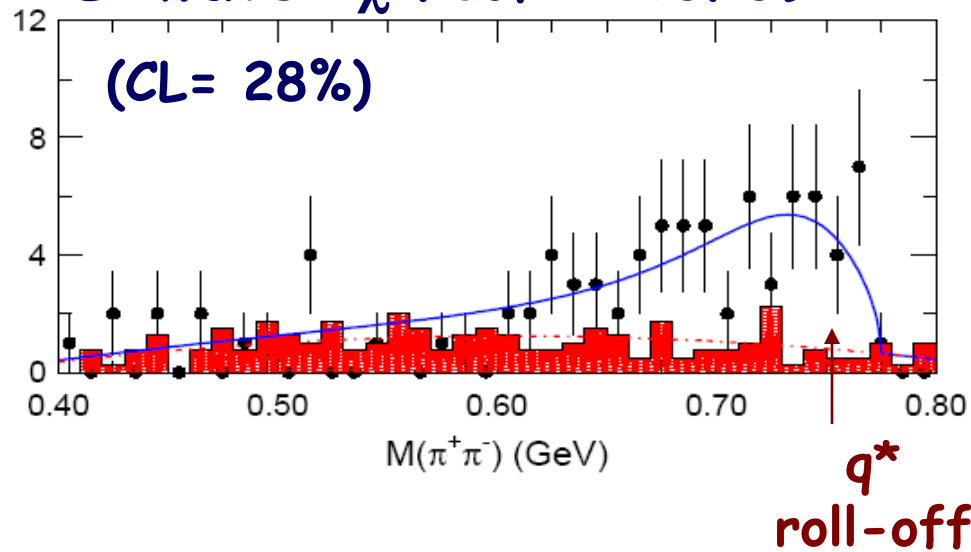

P-wave:  $\chi^2/\text{dof} = 71/39$

(CL=0.1%)

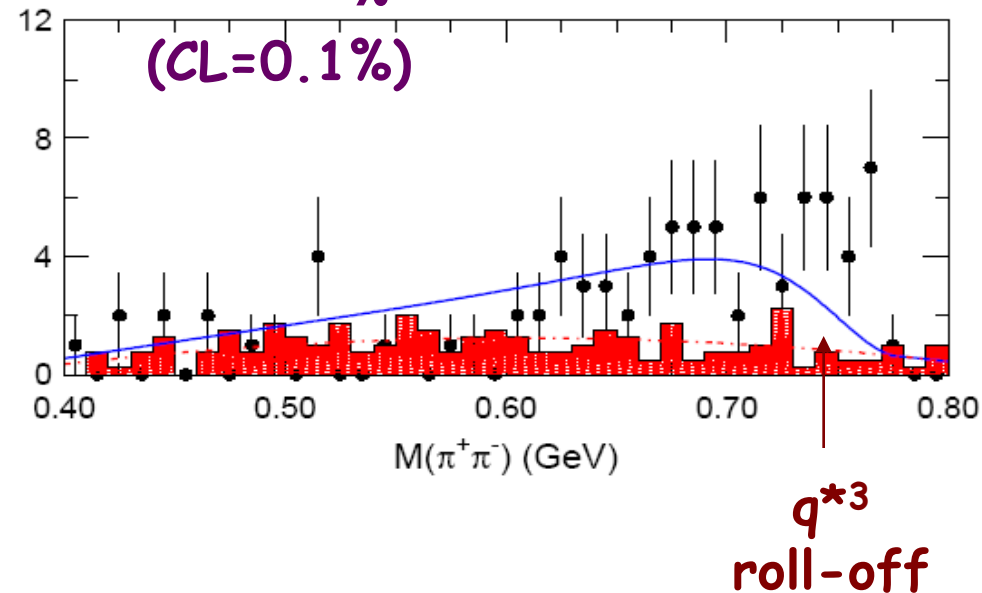

Shape of  $M(\pi\pi)$  distribution near the kinematic limit favors S-wave

# Recent studies on X(3872)

- BaBar confirms that, and
- BaBar (and Belle) are studying on  $\overline{D^0}D^0\gamma$  to clarify about  $DD^*$  component
- A new idea:
- X(3872) is (merely)
- a virtual state (propagator)
- of  $\overline{D^0}D^{*0}$
- to explain the mass shift
- [arXiv:0704.0605\[hep-ph\]](https://arxiv.org/abs/0704.0605)

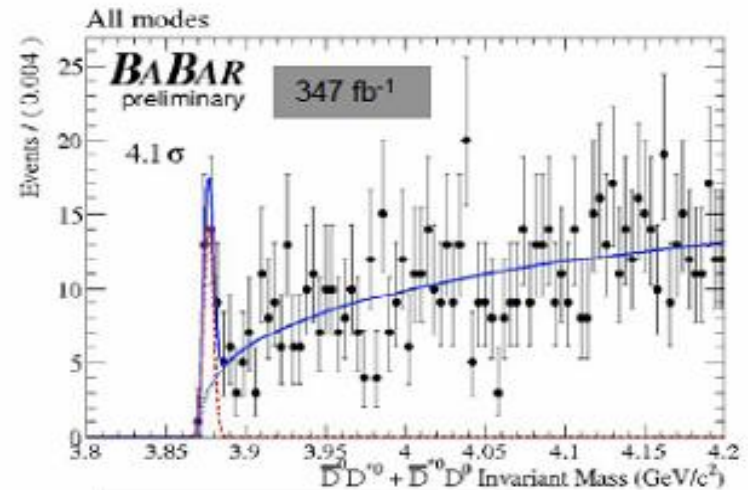
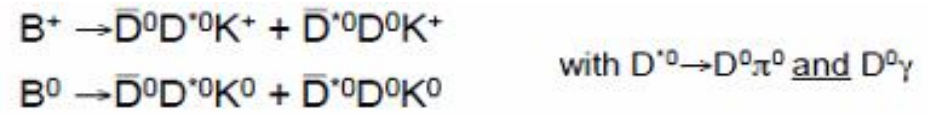

$$M = 3875.6 \pm 0.7_{-1.5}^{+1.4} \text{ MeV}/c^2$$

$$R(B^0/B^+) = 2.23 \pm 0.93 \pm 0.55$$

$$\Delta m(B^0/B^+) = 0.2 \pm 1.6 \text{ MeV}/c^2$$

$$\text{also: } \psi(3770) \rightarrow \overline{D}D : M = 3777.5 \pm 3.2 \text{ MeV}/c^2$$

Recent precise mass measurement of  $D^0$



Still within the error of  $M(\overline{D^0}D^{*0})$

# Y(4260) at Belle

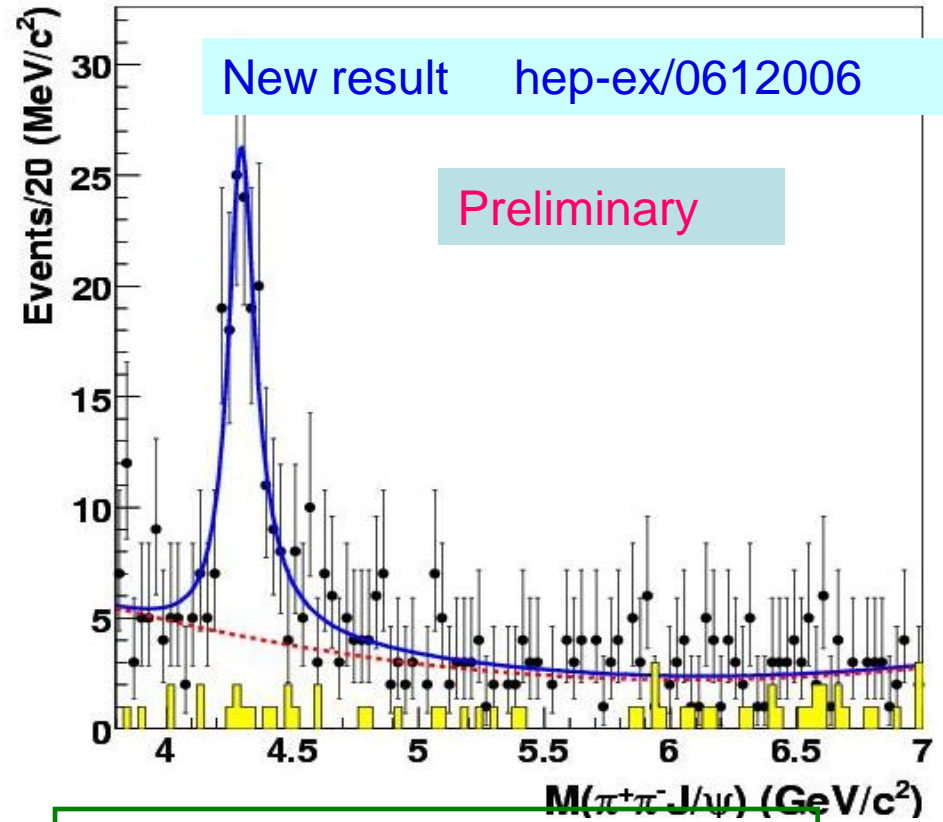
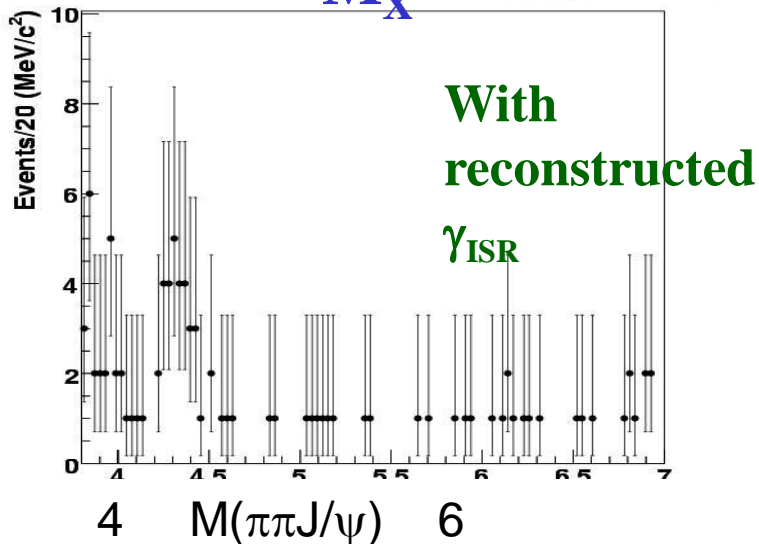
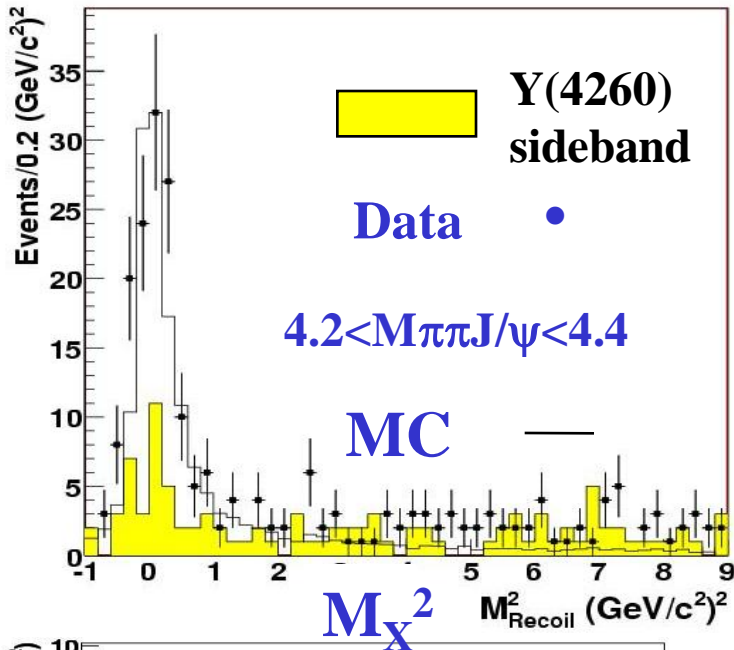

$$M = 4295 \pm 10^{+11}_{-5} \text{ MeV}$$

$$\Gamma = 133^{+26+13}_{-22-6} \text{ MeV}$$

$$\text{Yield} = 165^{+24+7}_{-22-23}$$

# $e^+e^- \rightarrow \gamma_{\text{ISR}} Y(4260)$ at BaBar/CLEO

First observation : BaBar PRL95, 142001 (2005)

$$\sigma(e^+e^- \rightarrow \gamma_{\text{ISR}} \pi^+\pi^- J/\psi) \sim 50 \text{ pb}$$

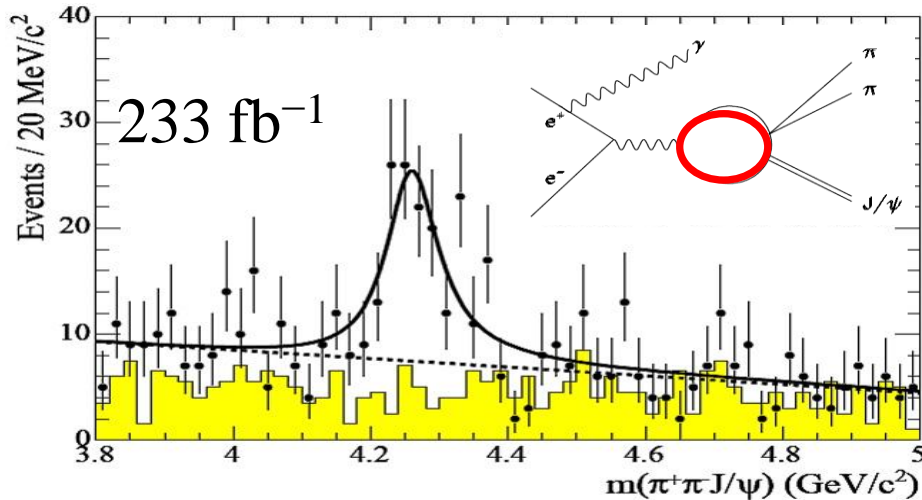

$$\Gamma(Y4260 \rightarrow \pi^+\pi^- J/\psi) > 1.6 \text{ MeV} @ 90\% \text{ CL}$$

	BaBar	CLEO III
$N$	$125 \pm 23$ ( $\sim 8\sigma$ )	$14.1^{+5.2}_{-4.2}$ ( $4.9\sigma$ )
Mass (MeV)	$4259 \pm 8^{+2}_{-6}$	$4283^{+17}_{-16} \pm 4$
Width (MeV)	$88 \pm 23^{+6}_{-4}$	$70^{+40}_{-25} \pm 5$

PRL96, (2006) 162003

CLEO : Also seen in energy scan, large  $\sigma(e^+e^- \rightarrow \pi^+\pi^- J/\psi)$  at  $E_{\text{CM}} = 4260$  ( $11\sigma$ ) Other decay modes  $\pi^0\pi^0 J/\psi$  and  $K^+K^- J/\psi$

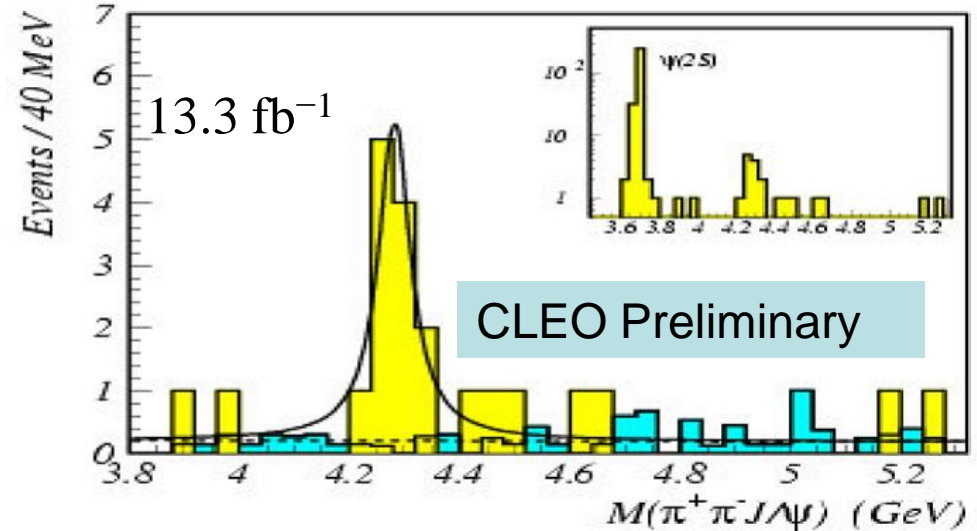

Not seen in  $e^+e^- \rightarrow \text{hadrons}$

X.H. Mo *et al*, PLB640, 182 (2006)

